

# TRICEL

GENERATIONS OF INNOVATION

# Tricel Maxus Combi Installation Manual

Wastewater Treatment System for 50+ Population Equivalent

*Engineering a green future*



# Table of contents

1	Introduction .....	5
1.1	Maximum load .....	5
1.2	Operation cost .....	5
2	Precautions when working with wastewater .....	6
3	System .....	7
3.1	Configurations.....	7
3.2	Process.....	8
3.3	Features – Model A .....	9
3.4	Features – Model B .....	10
4	Installation .....	11
4.1	Foundation.....	11
4.1.1	Concrete specifications.....	11
4.2	Unloading the Combi unit.....	11
4.2.1	Recommended handling tools (not included) .....	12
4.3	Control of packing list.....	14
4.4	Inspection of vital components.....	14
4.5	Installation of Combi .....	16
4.5.1	Placing the units .....	16
4.5.2	Securing the unit.....	17
4.6	Gravel specification .....	18
4.7	Concrete specification.....	19
4.8	Topsoil requirements .....	19
4.9	Connections.....	20
4.10	Control scheme - Installation.....	21
5	Commissioning.....	22
5.1	Electrical installation .....	22
5.2	Cable connection in switch socket .....	23
5.3	Electric diagram .....	23
5.4	Tricel control unit model E-VI.....	26
5.5	External alarm.....	26
5.6	The alarm unit.....	26
5.7	Inlet pumps .....	28
5.8	Filling the system with water .....	31
5.9	Blowers and aeration .....	32
5.10	Sludge re-circulation air lift pumps .....	34

6	Trouble shooting.....	36
6.1	Aeration.....	36
6.2	Sludge Return.....	37
6.3	Hydraulics.....	38
6.4	Quality of treated water.....	39
7	Operations and Maintenance .....	40
7.1	Water Samples .....	40
7.2	Confirmation of Connections.....	40
7.3	Inlet pumps.....	41
7.4	Blower .....	41
7.5	Septic Tank.....	42
7.6	Emptying the Septic Tank and Sludge Removal .....	43
7.7	Control Box.....	43
7.8	Recommended regular maintenance .....	43
7.9	Recommended Yearly Maintenance .....	43
7.10	Recommended Spare Parts List for Combi .....	44
7.11	Operation Without Wastewater for up to 6 Months.....	44

This manual concerns procedures and guidelines for installation, commissioning, operation, trouble shooting and maintenance of the Tricel Maxus Combi treatment plant. Instructions for pre and after-treatment, inlet pump system and other equipment included in the specific project are found in separate manuals.



# 1 Introduction

The Combi system is designed to treat ordinary household wastewater. Only domestic wastewater is permitted to enter the wastewater treatment plant unless specifically approved by Tricel.

## 1.1 Maximum load

The Tricel Maxus Combi systems allows for fluctuations in both concentrations and volume of the incoming water. However, if the average daily load exceeds the capacity of the designed system, a larger system must be installed.

## 1.2 Operation cost

System operation settings and power consumptions can be seen in the project specific commissioning, operation and maintenance manual.

## 2 Precautions when working with wastewater

### Protecting Workers from Infection

Along with “good” micro-organisms that break down sewage, wastewater contains disease-causing bacteria, viruses, fungi and parasites. When workers can't avoid contact with sewage, management should provide the following protective equipment and services:

- Elbow-length rubber gloves
- Protective clothing
- Goggles
- Disposable mask to be worn in dusty sludge areas or areas with heavy aerosols.
- Commercial high temperature washing machines for work clothing.

Workers should also take the following precautions:

- Wash gloves before removing them.
- Wash hands before smoking and eating.
- Keep protective clothing and equipment out of eating areas.
- Keep work clothes and street clothes in separate lockers.
- Shower and change into street clothes before going home.
- Consider all cuts or abrasions to be infected. Flush them with large amounts of clean, running water and soap, and bandage them with a sterile dressing.
- Workers should have a tetanus booster every 10 years and workers, who have never been vaccinated for polio, should consult a physician about getting a vaccination.
- Workers should receive the hepatitis A vaccination. Workers working in sewers that may contain fresh blood or come into regular contact with used syringes or body parts should receive the hepatitis B vaccination.
- Trucks that carry materials contaminated with sewage should be washed frequently.
- Records should be kept of workers' major and minor illnesses and complaints of irritation and discomfort.

Seek medical attention when you have diarrhea or are ill. Since doctors are often unaware of the connections between occupation and disease, be sure to inform your personal physician of job exposure to sewage.

# 3 System

## 3.1 Configurations

Combi comes in two different standard versions, Combi A and Combi B. Each version is available in 9 different standard sizes.

Combi A has a high inlet, whereas Combi B has a low inlet, making it easier for the wastewater to gravitate into the unit. Examples of the two different models are seen in Picture 1 and Picture 2.

For sizes, capacities etc. see separate Combi facts sheet.

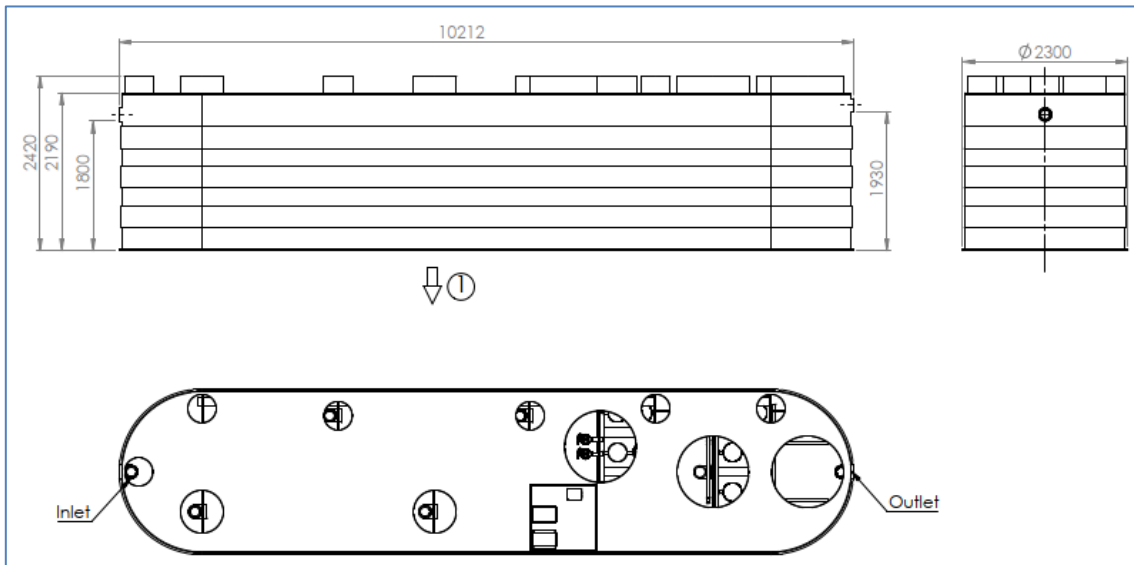

Picture 1 – Combi 6A

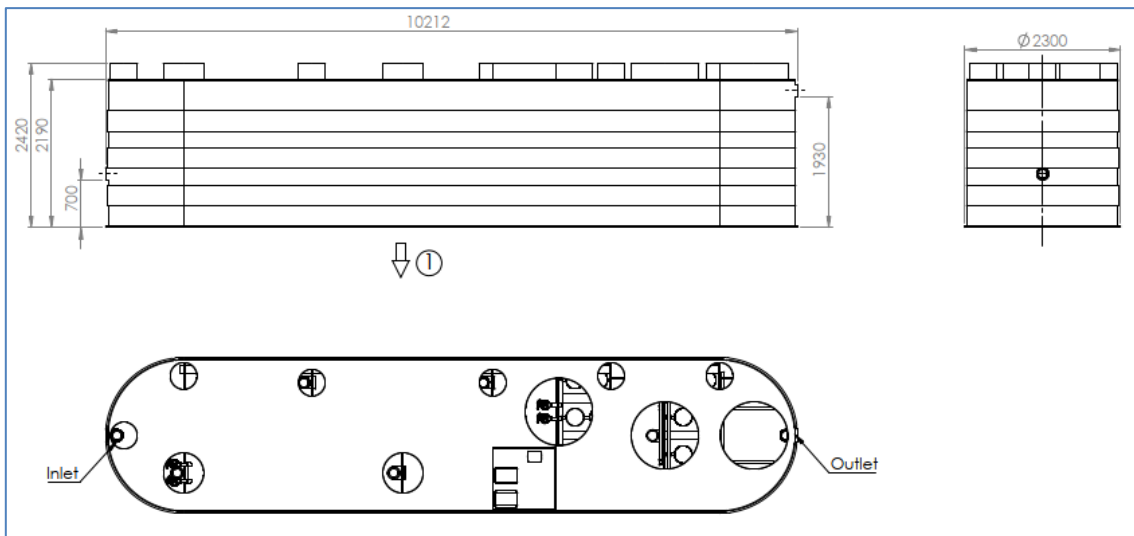

Picture 2 - Combi 6B

## 3.2 Process

1. The effluent enters the primary settlement chamber. Settlement occurs when the heavier solids drop out of the wastewater and settle to the bottom of the tank to create sludge, and the lighter solids float to the top of the water to create scum.
2. The buffer tank will even out any fluctuations for the incoming water load. A float switch close to the top of the buffer chamber works as a high-level switch and runs the inlet pump continuously if activated.
3. In the biological treatment zone, the submerged bioblock filter, with a large surface area for the microbes, is exposed to heavy aeration. The system will never clog and does not need any chemicals.
4. Bio sludge settles in the settling zone. Airlift pumps in the bottom keep the settling zone clean by recirculating the bio sludge to the settling tank.
5. If disinfection of the treated wastewater is required, the integrated chlorine dosing or UV-treatment system placed at the outlet ensures that no bacteria will leave the system. This is needed if the water is to be reused.



### 3.3 Features – Model A

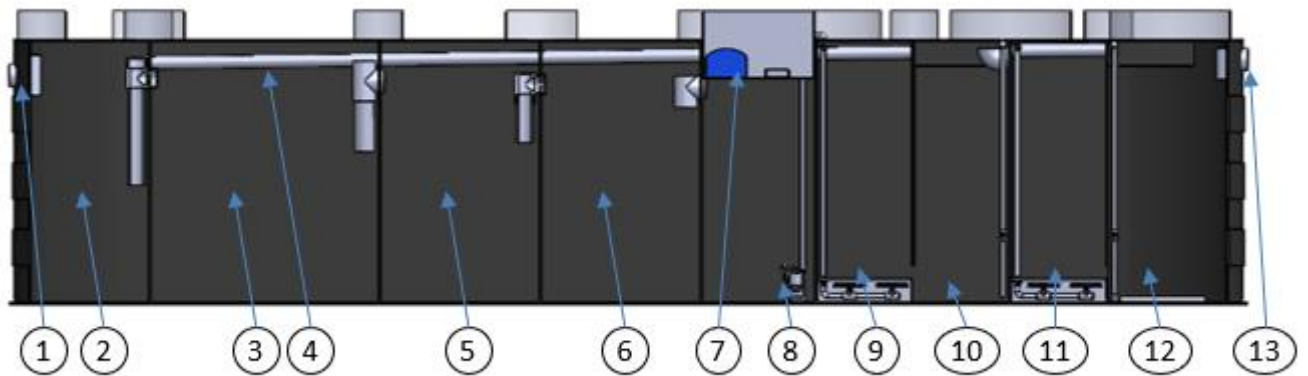

Item #	Function
1	Inlet
2	Septic tank chamber 1
3	Septic tank chamber 2
4	Sludge return pipe
5	Septic tank chamber 3
6	Septic tank chamber 4
7	Tech box w. blowers and controller
8	Buffer tank w. 2 x inlet pumps
9	Biozone 1
10	Clarifier 1 w. air lift pumps
11	Biozone 2
12	Clarifier 2 w. air lift pumps
13	Outlet

### 3.4 Features – Model B

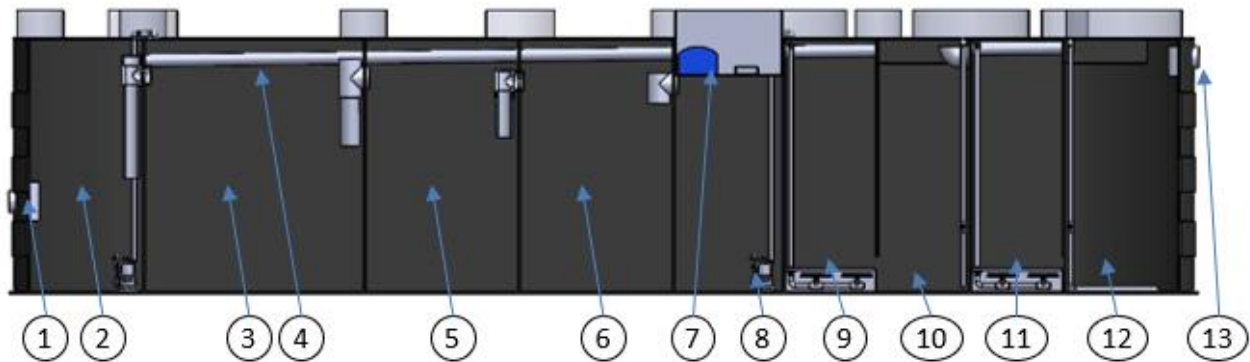

Item #	Function
1	Inlet
2	Pump well w. 2 x grinder pump
3	Septic tank chamber 1
4	Septic tank chamber 2
5	Sludge return pipe
6	Septic tank chamber 3
7	Tech box w. blowers and controller
8	Buffer tank w. 2 x inlet pumps
9	Biozone 1
10	Clarifier 1 w. air lift pumps
11	Biozone 2
12	Clarifier 2 w. air lift pumps
13	Outlet

# 4 Installation

## 4.1 Foundation

Civil works can be completed prior to the arrival of the Combi system, which will make the installation faster when the equipment is supplied.

The foundation must be leveled. Local norms and standards apply when determining design loads, material strength and dimensions of concrete and reinforcement.

The leveled load bearing surface with a maximum level variation of +/- 1 cm high per 4 meters across. Surface must consist of either (i) stable compressed gravel, (ii) concrete slab built on stable soil, or (iii) a checker plate capable of handling the load.

### 4.1.1 Concrete specifications

Semi-dry concrete 25n grade with a ratio of 4.5/1 parts aggregate to cement.



- Standard concrete mixes should not get used where sulphates or similarly aggressive chemicals are present in the groundwater.
- Lift height (rate of rise): Determine the lift height (m), or rate of rise (m/h) for the specific concrete type used, to ensure that a design pressure (P max) of 15kN/m<sup>2</sup> on the tank does not get exceeded.
- Vibration: The tank design assumes minimal compaction of the surrounding concrete. Where necessary, this may be extended to include internal light vibration. Never use deep revibration which will substantially increase the pressure on the tank, possibly causing failure.
- Impact of concrete on discharge: Under no circumstances should concrete be discharged directly onto the tank.

## 4.2 Unloading the Combi unit

The system will normally be shipped to site in a standard Eurotrailer. The tanks fit narrowly on the width of the truck. It is important that precaution is taken during unloading to avoid impact and damage on the tanks and equipment. Tank dimensions are found on the Combi fact sheet.



**Tricel do not accept liability for any damage caused during the offloading procedure.**

#### 4.2.1 Recommended handling tools (not included)

The system fits narrowly in trucks and standard shipping containers. It is important that precautions are taken during unloading to avoid impact and damage on the equipment.

The system comes with pre-installed lifting straps, installed around the tank. This makes it easy to handle the units when installing the equipment. Do not confuse the lifting straps with the ropes on the side of tank, which must not be used for lifting the system.

To facilitate the unloading, the tank is equipped with ropes on the side of the tank. These ropes are not to be used for lifting the tanks, but only to help dragging the tanks out of the container, see Picture 3.



**The ropes on the side of the tank may *never* be used for lifting the units.**



Picture 3

The safest way of transporting the system on site is by means of a mobile crane, fork lift truck or by use of fork lifts installed on an excavator or on a front loader, see Picture 4 – Lifting the Combi and Picture 5.

When using a forklift, make sure to use long forks.



**Lifting the Combi tanks shall be done heavy straps placed under the unit to ensure full support as shown in Picture 4.**

**Do not attach straps to any other part of the tank, and do not use yellow ropes to lift the Combi!**

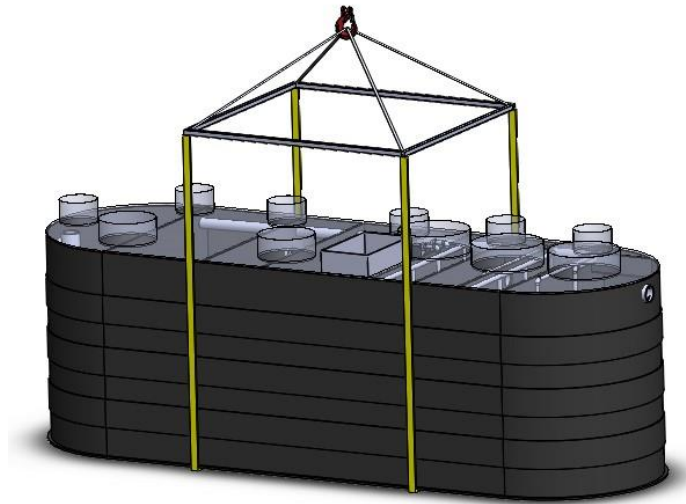

**Picture 4 – Lifting the Combi**

To avoid damaging the plastic welding while lifting the Combis, make sure that the straps used are minimum 2,5 metres long from each corner of the tank.

The straps can be inserted by tilting the unit one side at the time using the ropes connected on the side. The units must never be tilted more than 2cm when using the thin ropes.

If, for practical reasons, sufficient lifting height is not possible, we recommend attaching the straps to a yoke (steel frame) to avoid any deformation of the tank. (Yoke and straps are not included in the delivery).



**Picture 5**



**Notice: Do not lift the Combi units with water inside.**

### 4.3 Control of packing list

Always check that the components and parts received are in accordance with your order and packing list. Also ensure that the goods are without visible damages or faults.

All pipe dimensions in this manual is external diameter.

The check list on the last pages of this manual can be used when controlling the condition and quantities of the supplied equipment.

In the standard components for each model and size is shown. Control that the supplied equipment matches the model and size of Combi.

Table 1

Unit	Inlet pump well	Blowers	
3A	NA	1 x 400lpm	2 x 370W sewage pump
4A	NA	1 x 400lpm	2 x 370W sewage pump
5A	NA	2 x 300lpm	2 x 370W sewage pump
6A	NA	2 x 400lpm	2 x 370W sewage pump
7A	NA	2 x 400lpm	2 x 370W sewage pump
8A	NA	2 x 400lpm + 2 x 240lpm	2 x 370W sewage pump
9A	NA	2 x 400lpm + 2 x 300lpm	2 x 370W sewage pump
3B	2 x 550W grinder pump	1 x 400lpm	2 x 370W sewage pump
4B	2 x 550W grinder pump	1 x 400lpm	2 x 370W sewage pump
5B	2 x 550W grinder pump	2 x 300lpm	2 x 370W sewage pump
6B	2 x 550W grinder pump	2 x 400lpm	2 x 370W sewage pump
7B	2 x 550W grinder pump	2 x 400lpm	2 x 370W sewage pump
8B	2 x 550W grinder pump	2 x 400lpm + 2 x 240lpm	2 x 370W sewage pump
9B	2 x 550W grinder pump	2 x 400lpm + 2 x 300lpm	2 x 370W sewage pump

### 4.4 Inspection of vital components

#### Treatment Plant: Tricel Maxus Combi

Check all tanks and filters are not damaged in any way.

All equipment is installed internally in the Combi unit, so only connections are in- and outlet and main power to the control box.

#### Pump System

The system is delivered with an integrated pump system. Model A has two pumps installed in the buffer tank, while Model B has two pumps installed in the pump well and two pumps installed in the buffer tank. Check components for pump system are in accordance with check the list in this manual.

### **Float Switch System**

The float switch system consists of a bar where three independent float switches are placed. Check that components for pump system are in accordance with the check list in this manual.

Model B has in addition two float switches installed in the pump well for control of the two grinder pumps.

### **Air System**

Diaphragm blower(s) for air supply to the biological treatment is installed in the integrated control box and connected to the aeration piping. Control the blower(s) and air-pipes are intact and undamaged and in accordance with specs.

### **Electrical Cabinet**

Control that equipment in the technical box is undamaged.

### **Other parts**

Control that all remaining parts are undamaged and according to parts list.

## 4.5 Installation of Combi

The system must be installed according to guidelines described in the Combi design and layout manual or the project specific layout drawings approved by Tricel.

### 4.5.1 Placing the units

The unit is placed on a flat and leveled load bearing surface with a maximum level variation of +/- 1 cm high per 4 meters across. Surface must consist of either (i) stable compressed gravel, (ii) cast concrete slab built on stable soil, or (iii) a checker plate capable of handling the load, see Picture 6.

If the groundwater table is high, i.e. covers more than 300mm from the bottom of the plant, it's important that the ground around the unit is drained and sufficient groundwater lowering is done.



Picture 6



#### 4.5.2 Securing the unit

In areas where the groundwater table is high, the Combi must be kept in place and prevented from buoyancy.

To keep the units in position fill the tanks with approximately 750mm of water.

Construct the formwork for 200 to 250 mm concrete wall around the Combi tank. Use the Combi tank as the inner formwork. The concrete should cover at least the bottom 500mm of the tank in order to secure it from buoyancy, see Picture 7. Please note that for Combi B-versions, the concrete must not cover the low placed inlet pipe, i.e. maximum 650mm from the bottom.

Local guidelines and regulations concerning civil works apply.

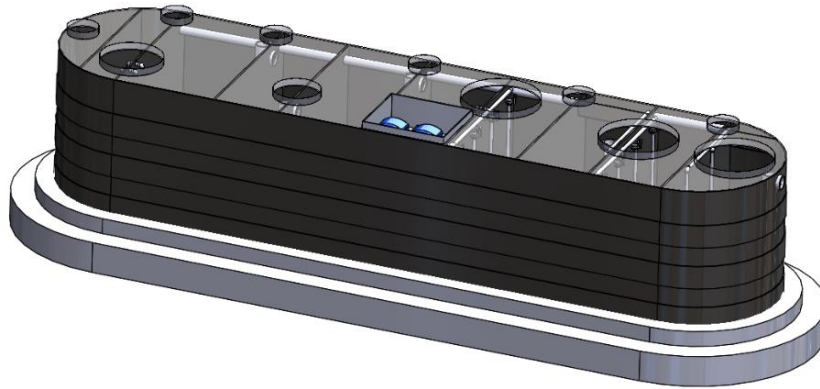

Picture 7

Fill the area around the tanks with gravel to support the units from the internal load, see Picture 8. The units shall be covered to **300mm** from the edge.

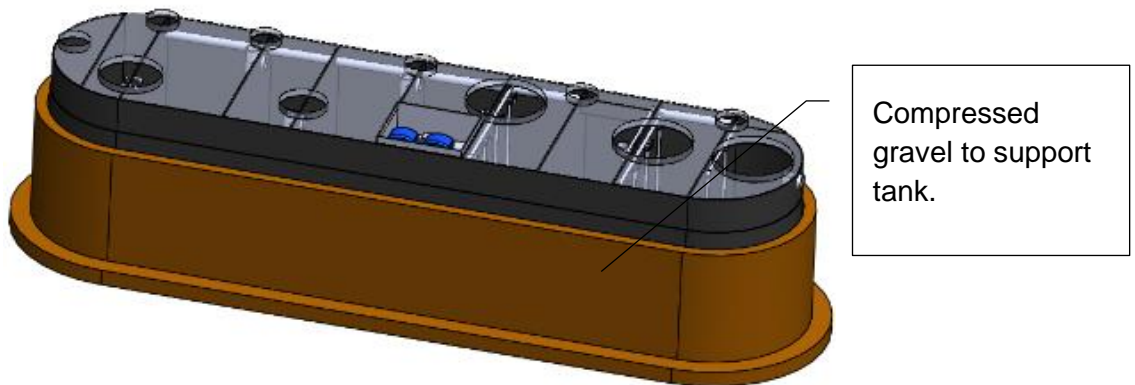

Picture 8



**Note! The Combi must not be installed above ground.**

## 4.6 Gravel specification

### Primary backfill specification

- Primary backfill material should be free-flowing granular material.
- Compaction should be by lightweight rollers or vibratory plate. Compact gravel evenly to ensure proper support for the tank. Ensure the vibrating machine does not come in contact with the shell of the tank.
- Tanks must get installed with primary backfill only within the region immediately surrounding the tanks. This primary backfill must extend a minimum of 250mm outward from the tank, and directly beneath it.
- Backfill material shall not be frozen or contain lumps of frozen material at any time during installation.
- Use of other than specified backfill and bedding materials will void the tank warranty.

The following materials have approval as primary backfill:

### Rounded pea gravel

- Minimum particle size 3mm, maximum 18mm, compacted to a relative density of >70%.
- Gravel shall be clean and free flowing, free from large rocks, dirt, sand, roots, organic materials or debris.
- Upon screening analysis, the backfill material shall have no more than 5% by weight passing 2.36mmsieve.

Or

### Crushed or processed stone

- Minimum particle size 3mm, maximum 12mm, compacted to a relative density of >40%
- Dry Gravel density must be at least 1500 kg/m<sup>3</sup>. The material should be washed or screened to remove fine particles.
- Upon screening analysis, the backfill material shall have no more than 5% by weight passing 2.36mm sieve.

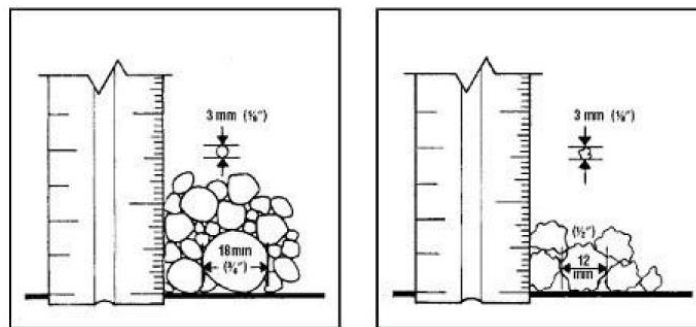

Pea Gravel

Crushed Stone

## 4.7 Concrete specification



**Semi-dry concrete 25n grade with a ratio of 4.5/1 parts aggregate to cement.**

**Important**

- Standard concrete mixes should not get used where sulphates or similarly aggressive chemicals are present in the groundwater.
- **Lift height (rate of rise):** Determine the lift height (m), or rate of rise (m/h) for the specific concrete type used, to ensure that a design pressure (P max) of 15kN/m<sup>2</sup> on the tank does not get exceeded.
- **Vibration:** The tank design assumes minimal compaction of the surrounding concrete.

Where necessary, this may be extended to include internal light vibration. Never use deep revibration which will substantially increase the pressure on the tank, possibly causing failure.

- **Impact of concrete on discharge:** Under no circumstances should concrete be discharged directly onto the tank.

## 4.8 Topsoil requirements

Clean native topsoil shall not contain rocks larger than 36mm on largest dimension.

**Note:** The use of geotextile barrier fabrics surrounding the primary backfill material is considered good installation practice. This fabric must be chosen to allow the flow of water in and out of the excavation but to prevent the movement of fine soil particles into the primary backfill material.

## 4.9 Connections

The Combi system comes as a complete wastewater treatment plant, and therefore only has three connections.

- Inlet pipe for raw sewage: Ø160 PVC.
- Power cable – For dimensions see electrical specifications, .
- Outlet pipe for treated sewage: Ø160PVC.

Ensure that the in- and outlet pipes are fixed, and that the water flows freely to and from the system.

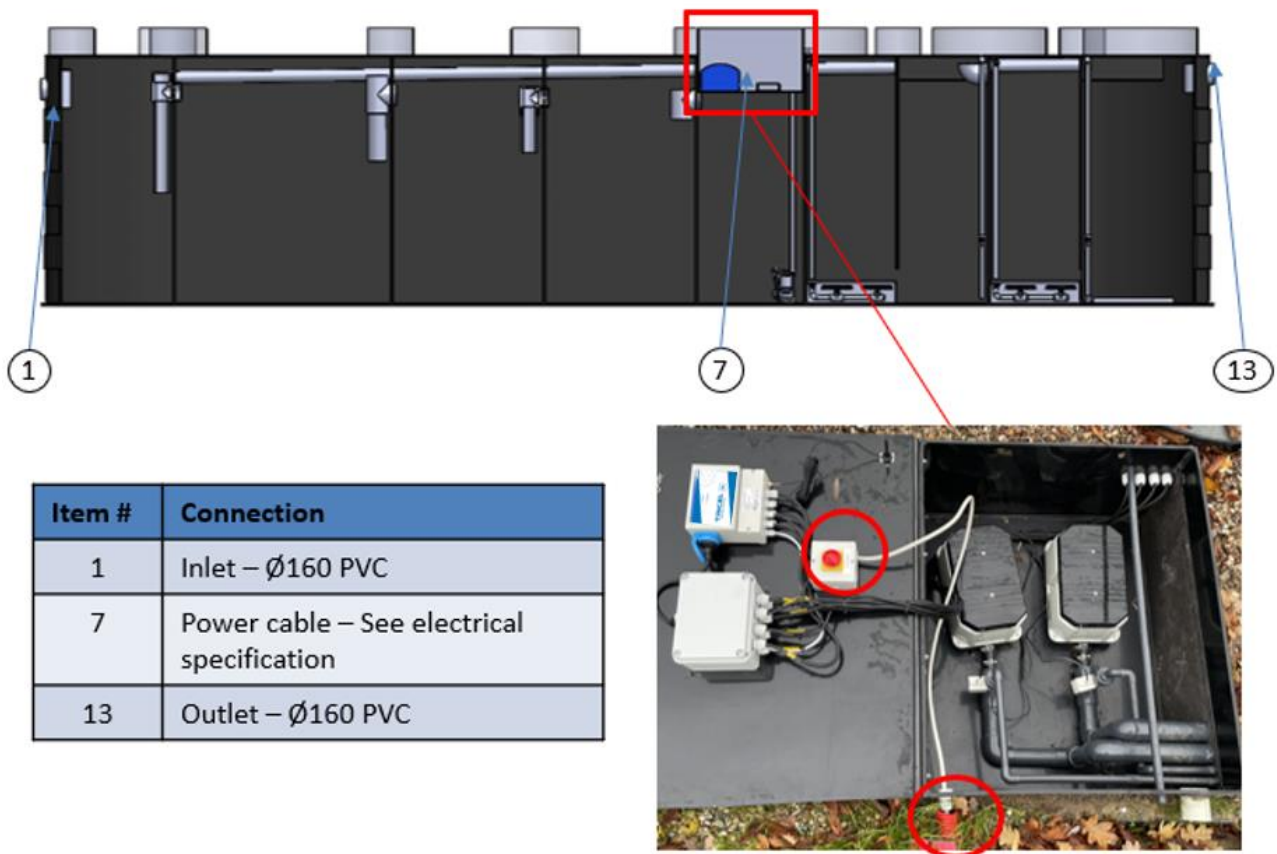

Picture 9

Table 2

Unit	Max Load	Power cable size	Alarm cable size
3A/B	2 x 5A	3 x 2,5mm <sup>2</sup>	2 x 0,75mm <sup>2</sup>
4A/B	2 x 5A	3 x 2,5mm <sup>2</sup>	2 x 0,75mm <sup>2</sup>
5A/B	2 x 10A	3 x 2,5mm <sup>2</sup>	2 x 0,75mm <sup>2</sup>
6A/B	2 x 10A	3 x 2,5mm <sup>2</sup>	2 x 0,75mm <sup>2</sup>
7A/B	2 x 10A	3 x 2,5mm <sup>2</sup>	2 x 0,75mm <sup>2</sup>
8A/B	2 x 10A	3 x 2,5mm <sup>2</sup>	2 x 0,75mm <sup>2</sup>
9A/B	2 x 10A	3 x 2,5mm <sup>2</sup>	2 x 0,75mm <sup>2</sup>

#### 4.10 Control scheme - Installation

ID (SECTION)	TASK	REFERENCE DOCUMENTS	ACCEPTANCE CRITERIA
4	Follow instructions in section 3.1 prior to installing the equipment	Project specific layout drawings	Civil works is made according to project specific layout and no cracks or similar deviations are observed
4.3	Follow instructions in section 4.3 after equipment has arrived to customer	Project specific parts list and packing list	Supplied equipment is according to Specific parts list and packing list
4.4	Follow instructions in section 4.4 after equipment has arrived to customer	Project specific parts list and packing list	No damages or errors are observed on the supplied equipment
4.5	Follow instructions in section 4.5 when installing the system	Project specific detail drawings	the system is installed according to detail drawings and this manual

# 5 Commissioning

## 5.1 Electrical installation

The control box is in the electrical cabinet integrated into the system. All electrical components in the system are powered through the control box, which is connected directly to the power supply, see Picture 10.

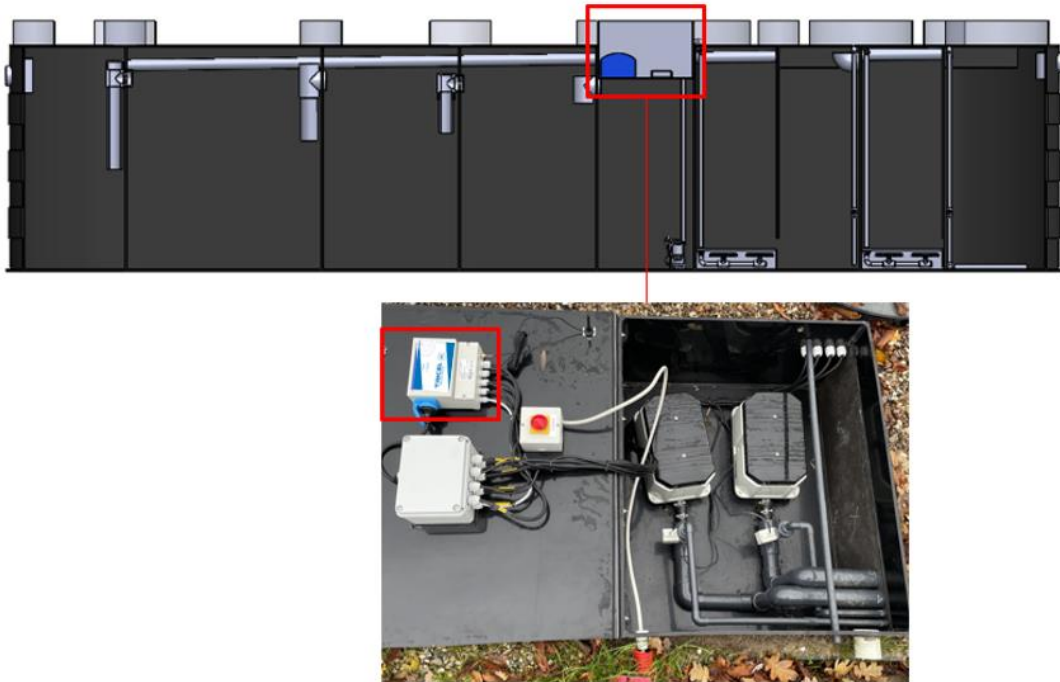

Picture 10

Minimum requirements for the power supply cables are seen in Table 2. The cables are placed in the steel pipe going to the technical box, see Picture 9.

Tricel Maxus Combi alerts via a howl driven by a battery in the control itself in the event of a power failure. A separate circuit breaker of 10/13 amp is recommended in the HFI relay, for the group that Tricel Maxus Combi is connected to.

Tricel Maxus Combi's are powered with 230, 1 phase power supply. The maximum current is 5-10 Ampere, depending on the number of pumps installed. The draw of maximum current occurs only while starting the inlet pump. For the continuous use of blowers, the Tricel Maxus Combi only uses 400-1700 watt.

It's recommended that the Tricel Maxus Combi is connected to a separate fuse in the electrical panel, which will ensure that issues can easily be isolated in the event there's a problem with the power supply to the treatment plant.



**All electrical work must be done by a certified electrician. Maximum voltage loss in cable may not exceed 10 V.**

**Power supply cable is not included. Length of the 3-core supply cable to be determined on site based on distance to power source.**

## 5.2 Cable connection in switch socket

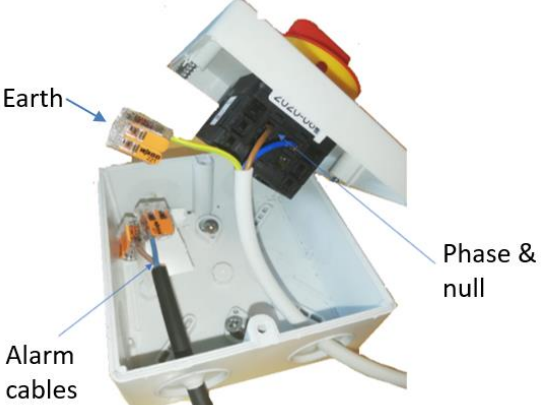

In addition, the 2 two 0.75 mm<sup>2</sup> alarm cables are connected to the corresponding + and - cable terminals, which are also routed through the box to the switch. See picture.

Clamp number	House installation	
Earth	Earth	
2	L, Phase 230 volts	
4	N, null	

## 5.3 Electric diagram

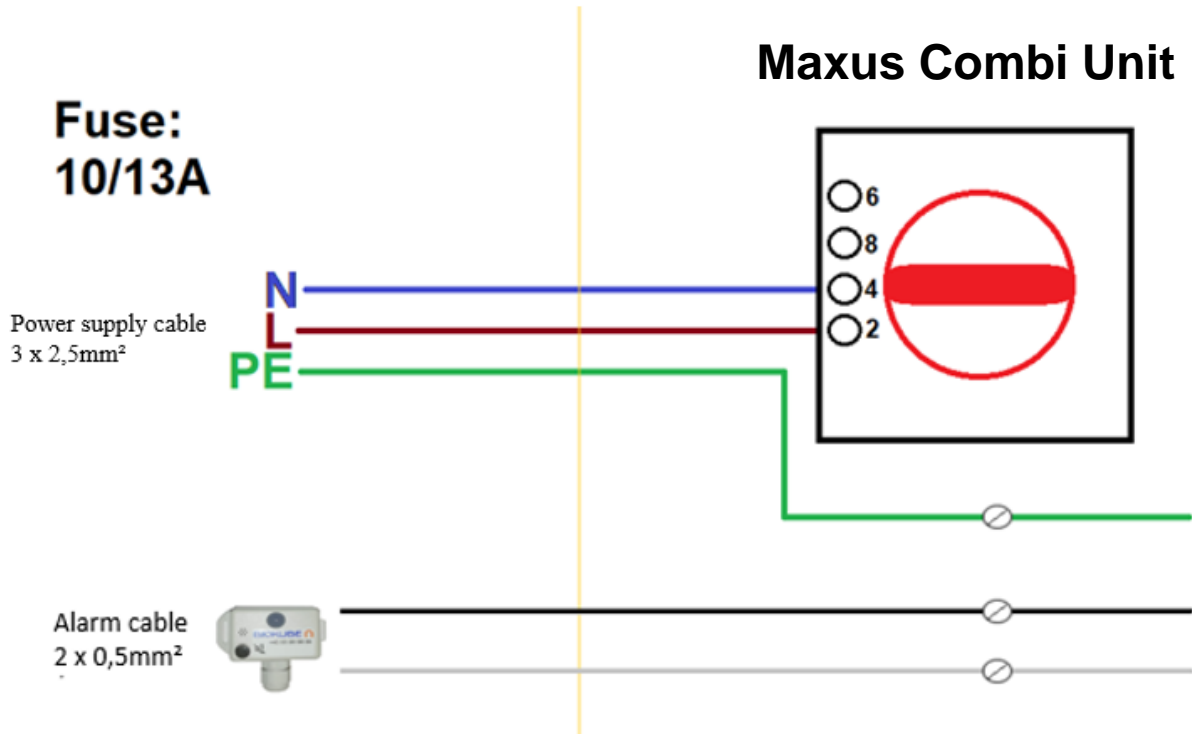

Electrical equipment installed in the system is connected in the electrical connection box installed in the tech box, see Picture 11 and Table 3.

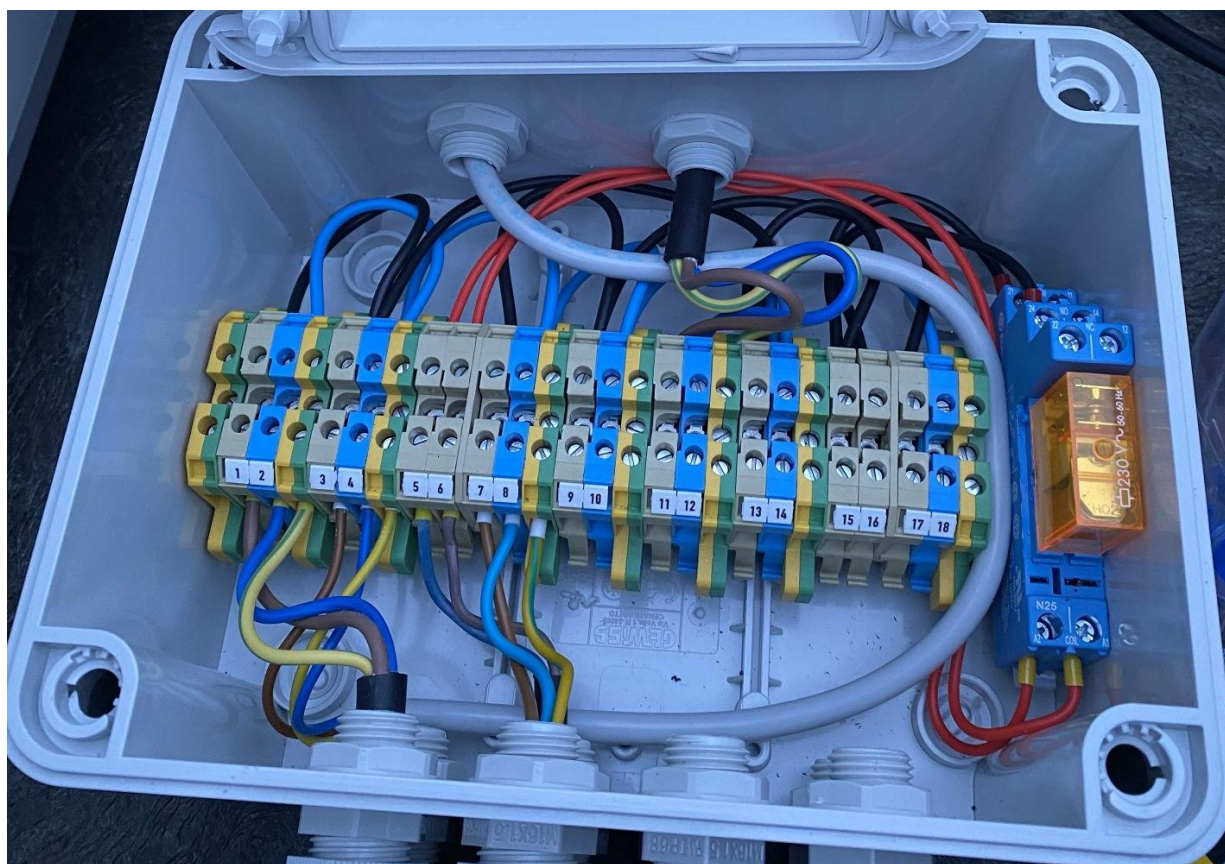

Picture 11

Table 3

#	Connection
1 & 2	Main power
3 & 4	Power supply to PLC
5 & 6	Output from PLC
7 & 8	Blower 1
9 & 10	Blower 2
11 & 12	Inlet Pump 1
13 & 14	UV lamp
15 & 16	Float switch 90%
17 & 18	Inlet pump 2



Picture 12 show the tech box, and what equipment is installed.

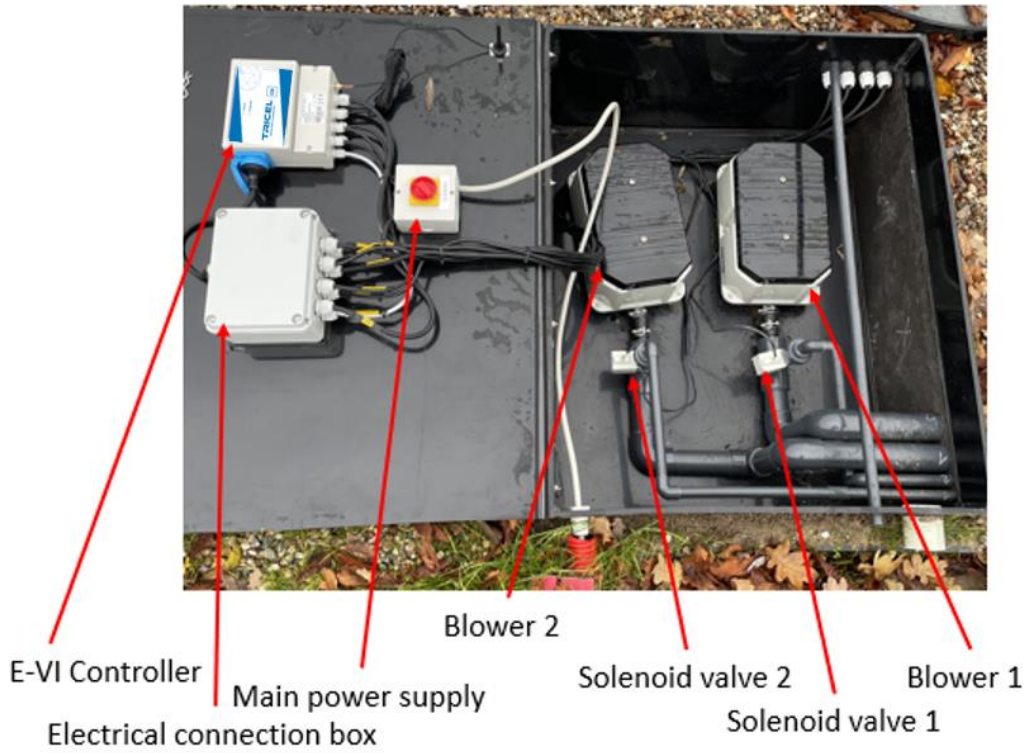

Picture 12

The system is switched on by turning the main switch in the technical box, see Picture 13.



Picture 13

## 5.4 Tricel control unit model E-VI.

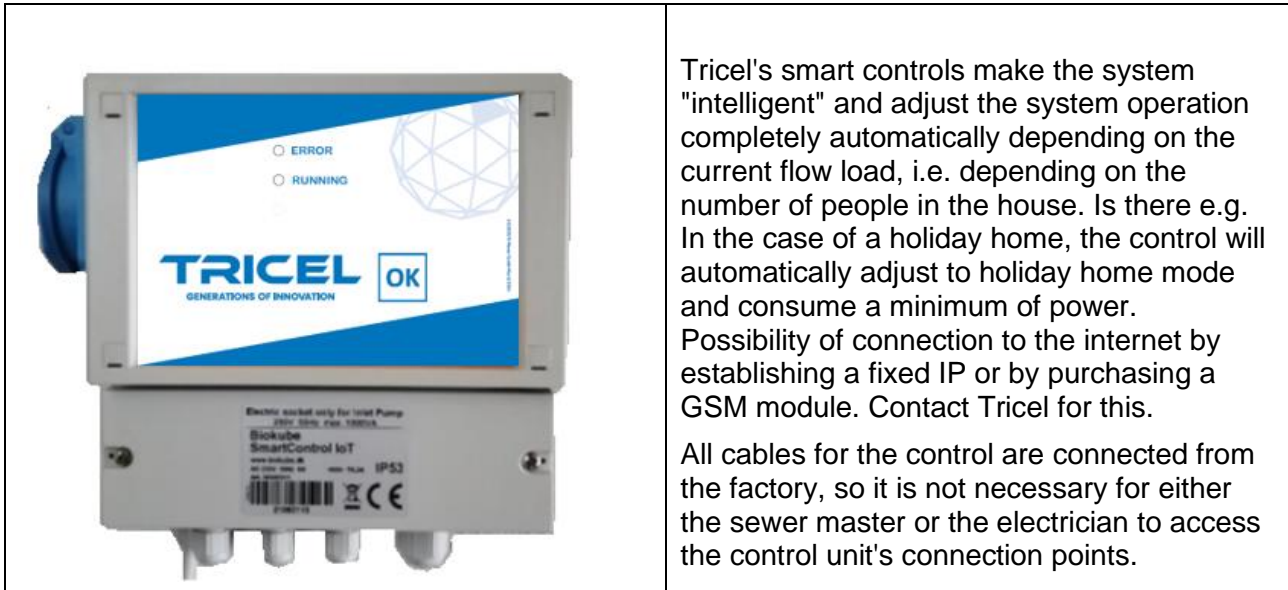

## 5.5 External alarm

A total of two cables are routed from the house to the system. A cable for power supply, and a cable for alarm.

**Power supply:** A 3-wire min. 2.5mm<sup>2</sup> cable is pulled from house to system and led into the system's technical room through cable entry pipes. No extra holes may be drilled in the system.

**Alarm cable:** A 2-wire min. 0.5 mm<sup>2</sup> is drawn from the system to the place where the alarm is to be placed. The location of the alarm is recommended to be a place where you have daily movements.

Ventilation of the technical box must not be closed, as this ensures air supply to air fans in the system.

## 5.6 The alarm unit

The alarm unit is recommended to be located indoors, a place where you have daily activities. It can be in the entrances or near the house's fuse box. The alarm is supplied by a 2 x 0.5 mm<sup>2</sup> low voltage cable. See user guide for information on alarm signals and their meaning.



### Alarm in the house:

The lamp is off, and the alarm is silent during normal operation. In the event of a fault in the system, it will flash and there will be a howling sound. This sound is muted by pressing the small black power button.

### Alarm in the system:



The green LED next to "Running" lights up during normal operation. In the event of an alarm, the "error" lamp will flash.

### Alarm signals are as follows:

Blink	Alarm type	What do the alarms mean?
Constant blink	Power failure to the system	No power, resets automatically
2 blink	Flows active at the same time as low pump power	Error in floating
3 blink	High level (floats active for 10 min)	Level does not drop even when the pump is running
4 blink	Inlet pump, low current level	Pump defective
5 blink	Inlet pump, high current level	Pump shorted
6 blink	Fan, low power level	Blowing defective
7 blink	Fan, high power level	Blowing short circuit
8 blink	Fuse burned	Internal security has blown
9 blink	Missing / dead battery	Battery is dead or not connected

## 5.7 Inlet pumps

### Combi – Model A

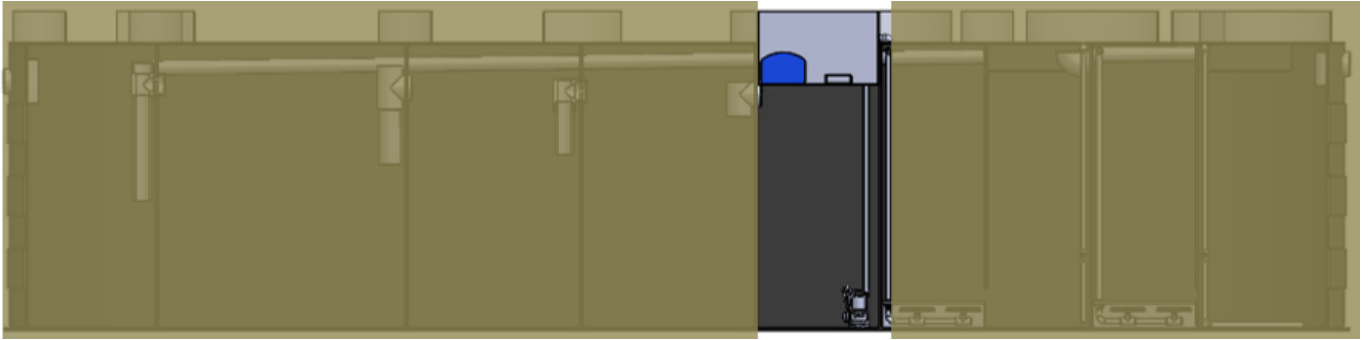

### Combi Model A – Buffer tank

In Combi – Model A, two Inlet pumps are installed in the buffer tank, along with three float switches. Control that pumps are correctly installed and secured, and that float switches are placed at approximately 10%, 75% and 90% of the height, see Picture 14.

Test the function of the float switches and pumps by lifting the float switches individually.

- Active the bottom float switch to check if inlet pump 1, duty pump, is running according to the timer.
- Active the middle float switch to check if inlet pump 1, duty pump, is running continuously after the end of the cycle. Activating the float switch will not force the pump to run, but will extend the duration of the pump cycle. If the middle float switch is activated After three pump cycles the alarm will go off.
- Activate the top float switch to force pump 2, stand-by pump.

## Combi – Model B

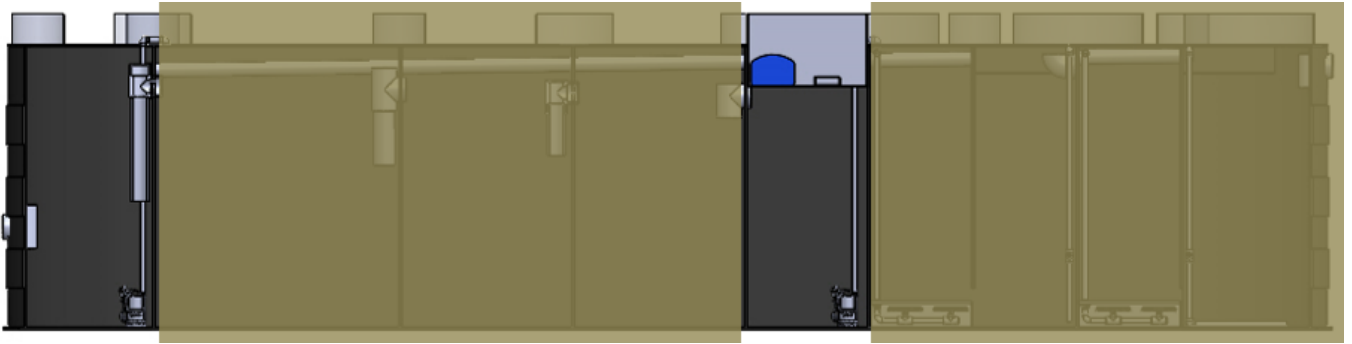

### Combi Model B – Inlet pump well

In Combi – Model B, two pumps are installed in the pump well in the first chamber, along with two float switches. Control that pumps are correctly installed and secured, and that float switches are placed at approximately 10%, 50% of the height to the inlet pipe, see Picture 15.

Test the function of the float switches and pumps by lifting the float switches individually.

- Lift the bottom float switch to force pump 1 to activate.
- Lift the top float switch to force pump 2 to activate.

### Combi Model B – Buffer tank

Furthermore, Two Inlet pumps are installed in the buffer tank, along with three float switches. Control that pumps are correctly installed and secured, and that float switches are placed at approximately 10%, 75% and 90% of the height, Picture 14.

Test the function of the float switches and pumps by lifting the float switches individually.

- Active the bottom float switch to check if inlet pump 1, duty pump, is running according to the timer.
- Active the middle float switch to check if inlet pump 1, duty pump, is running continuously after the end of the cycle. Activating the float switch will not force the pump to run, but will extend the duration of the pump cycle. If the middle float switch is activated After three pump cycles the alarm will go off.
- Activate the top float switch to force pump 2, stand-by pump.

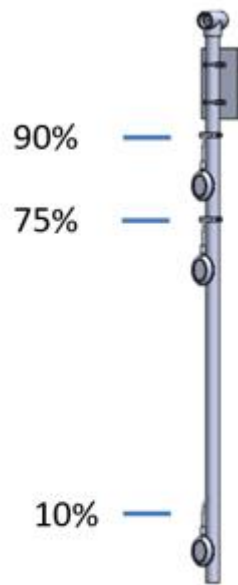

Combi - Model A/B  
Buffer tank

Picture 14



Combi - Model B  
Inlet pump well

Picture 15

## 5.8 Filling the system with water

After the system is installed in-ground and secured from buoyancy, it's filled with freshwater or technical water (treated sewage).

If there's no access to fresh water, please contact Tricel.

The system must be filled with 50cm of water at the time, as shown in Picture 16, Picture 17 and Picture 18, until the system is full, with exception of the buffer tank, which should only be half full, when the system is commissioned.

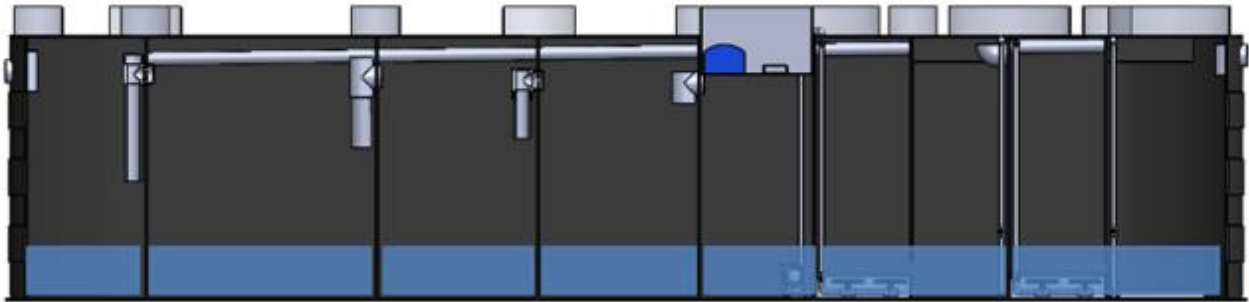

Picture 16

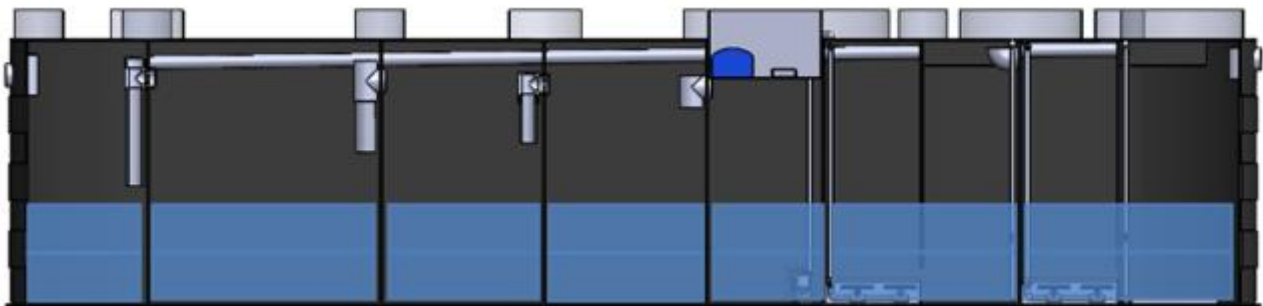

Picture 17

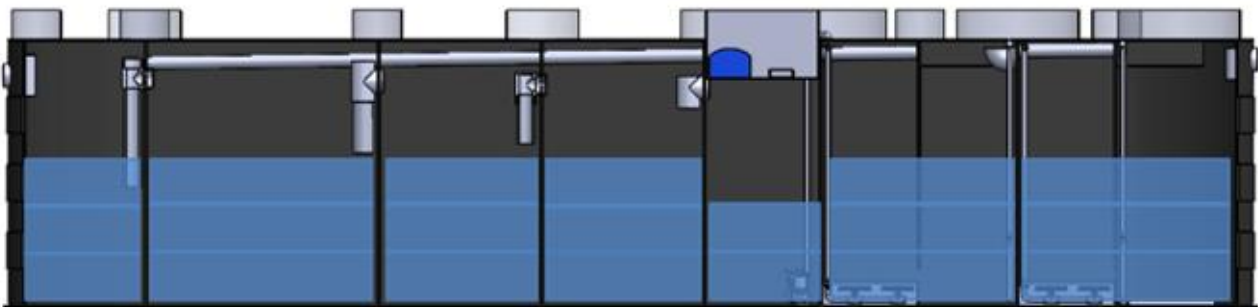

Picture 18



It is important that water filling has taken place prior to switching on the system.

## 5.9 Blowers and aeration

Blowers are installed in the technical box, see Picture 19.

Control that blowers and aeration piping is secured and fittings are tightened.

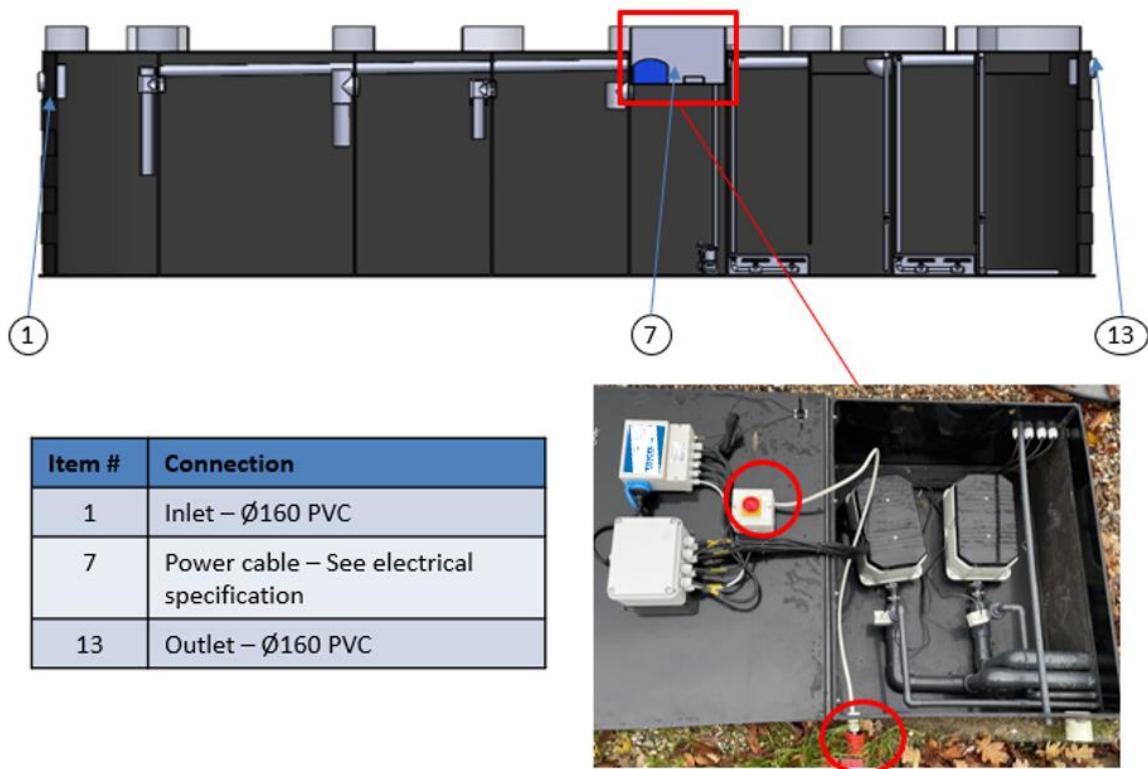

Picture 19

The biological treatment of sewage is secured by bacteria cultures that build up on the filter media in the treatment tank.

The build-up of bacteria is ensured by the aeration of the bio-zones.

To ensure the overall functionality of the system, it is important to pay special attention to the aeration process.

When the blower is in operation, air is led to diffusers in the bottom of the bio zone. The air is evenly distributed to the system if you observe equally sized air bubbles all over the treatment chamber, see Picture 20





**Picture 20**

Initially you might experience that not all diffusers are in operation. When sufficient pressure is built up this situation should however change. Please control again after 30 minutes.

Until the bacteria culture is sufficiently effective, the aeration of the sewage can create a certain amount of foam, see Picture 21. This is normal and will diminish after a short while.

Depending on the temperature of the sewage, the biology is fully operational after a period of two to six weeks.



**Picture 21**

### **Treated water outlet.**

The Tricel system will treat the sewage biologically. The technology is based on bacterial growth on the submerged aerated filter-blocks, see Picture 22 & Picture 23.

The bacteria originates from the content of the sewage, and for this reason it will need a period of one to six weeks to fully build up to treat the sewage to the required standard.

If local regulation allows for outlet of partly treated sewage, the outlet pipe can be connected directly to recipient during installation.



**Picture 22**



**Picture 23**

## **5.10 Sludge re-circulation air lift pumps**

To avoid accumulation of biological sludge in the system, each clarifier chamber is equipped with top and bottom air lift pumps, see Picture 24. The air pipes/hoses supplying air to the air lift pumps are connected directly to solenoid valves placed on the air blower. Air supply to the two air lift pumps in a clarifier is supplied with air from the same connection.

Timing of air lift pumps can be adjusted in the control box.

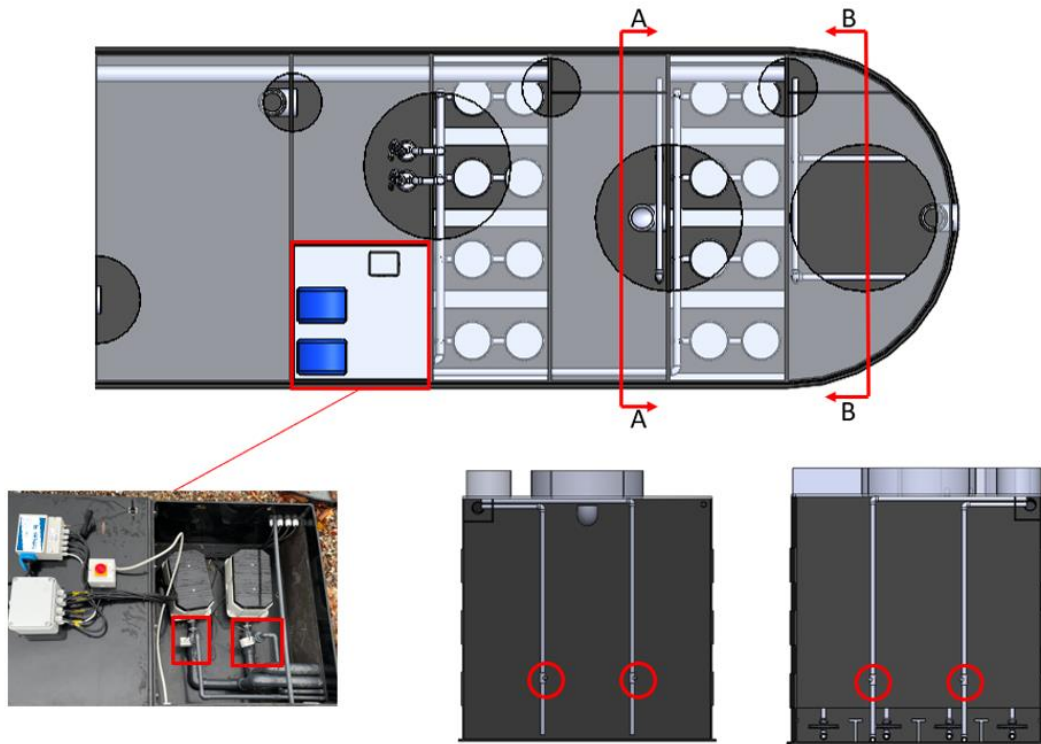

Picture 24

The return sludge water is collected in a chamber inside the Combi from where the return piping is connected to first chamber at the inlet, see Picture 25.

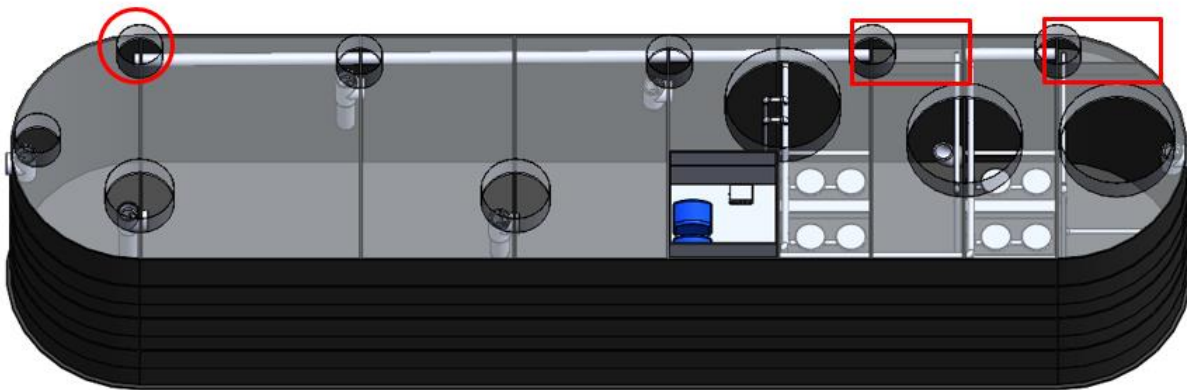

Picture 25

Control scheme – Commissioning

ID	TASK	REFERENCE DOCUMENTS	ACCEPTANCE CRITERIA
5	Follow instructions in section 5 when commissioning the system	NA	The system is in operation and no problems are observed

## 6 Trouble shooting

### 6.1 Aeration

When the blower is in operation, air is led to diffusers in the bottom of the bio-zone. Air is evenly distributed to the system. The oxygen level must be above 70 % in all aerated chambers. Trouble with poor or insignificant aeration in the Combi system can be related to failure of the blower, controller, air pipes and diffusers or to an overload of the system.

Problem	Observation	Cause	Control	Action
Oxygen level below 70 %	Full aeration	Possible overload of the system	Inlet values	See 7.1 Water Samples
	No or little aeration	The blowers	Make sure the blowers are in operation.	Confirm that the blower runs with normal sound and read the pressure on the manometer. Normal pressure is 0.2 – 0.7 bar depending on the system. If necessary, maintain the blower following maintenance manual.
		The air distribution system	Make sure the air distribution system piping is connected correctly and that no leakages occur.	Feel and listen for any leaks in the air line piping from the blower and to the diffusers. Repair if leaks are found.
		The diffusers	Some diffusers are not working.	Double the aeration for a few minutes by closing the manual valves in other parts of the system, alternatively push carefully on the top of the diffusers using a stick through the bio-zone. It's important that all valves are never all closed at the same time.
		The bio-zone	Sludge has clogged the bio-zone.	Double the aeration for a few minutes by closing the manual valves in other parts of the system or by cleaning the bio-zone with high water pressure.

When the problem is determined and solved, remove any accumulated sludge and the operation of the system can continue.

## 6.2 Sludge Return

The sludge return system pumps the biological sludge, produced by the bacteria, out of the clarifiers. This ensures optimal performance of the plant and is critical to the proper functionality of the system. Ensure that a maximum of 20 cm of biological sludge accumulates on the bottom of the clarifiers. If the level increases above 20 cm, change the settings of the sludge return frequency. Trouble with sludge in the biological treatment system can be related to the failure of the controller, magnetic valve, blower or air lift pipe.

Problem	Observation	Cause	Confirm	Action
Sludge return	Sludge in the system	Air lift pump is working	Settings of the airlift pump	Change settings to open the valve for the air lift pump for a longer period or more frequently.
		Air lift pump is not working	Controller is on	If controller is off, turn on the controller.
			Solenoid valve on the blower is working	Turn off the 16mm flexible hose and wait for 15 minutes until the controller activates the valve. Confirm that a large flow of air leaves the valve when activated.
			Functionality of air lift pump	Remove the air lift pump system from the tank and clean the sludge return pipes.

When the problem is determined and solved remove sludge from the Combi and clean the system with high pressure water before starting back up.

### 6.3 Hydraulics

It is important that the buffer tank functions properly so that the inlet flow is distributed equally. If peak flows can flow directly through the treatment plant, the plant will not treat the sewage as designed. The wastewater should be pumped automatically into the plant at regular intervals and the water level in the buffer tank is expected to be low under normal operation.

Hydraulic problems can occur, when large volumes of wastewater are pumped through the system over a short period or if pipes clog up.

Problem	Observation	Cause	Confirm	Action
Hydraulic overflow	Pre-treatment	Level continuously high	Controller is on and pump P1 starts automatically	Check alarm in the control box, and that pump P1 pumps starts automatically
		Level is normal but rises when pumping in	Make sure no pipes are clogged	Check all pipes including pipe from pre-treatment to treatment system and outlet pipe
	Treatment system	Water level rises to high when pumping in	Make sure no pipes are clogged	Check all pipes including pipe from pre-treatment to treatment system and outlet piping

When the problem is found and solved, remove any sludge from the Combi system and the operation of the system can continue.

## 6.4 Quality of treated water

If the water quality requirement of the treated water is not met, the inlet load of the plant needs to be investigated (volume, organic content or inhibitors) and the mechanical and electrical equipment need to be confirmed.

Precaution	Actions
Confirm the mechanical/electrical equipment following the maintenance manual	If defect components are observed, replace the component.
Confirm sufficient pre-treatment in the septic tank following the maintenance manual.	If any deviations are found, correct these. If the septic tank is full, it must be emptied.
Measure sludge in the clarifiers.	Not more than 20 cm biological sludge on the bottom of the clarifiers is allowed, if more is observed remove sludge manually with a pump and adjust sludge return timing in the control box.
Measure floating sludge in the plant	No floating sludge is accepted in the last chamber, if observed remove sludge manually and adjust sludge return. See maintenance manual.
Measure the oxygen level	The oxygen level must not be below 70%, if measured below change the blower and air hoses.
Measure the pH level	The pH value must not be below 6,5 or above 8,5, if observed otherwise the pH must be stabilized.
Measure the inlet flow	The inlet flow must be stable and not higher than what the plant is designed for.
Sample the incoming water	Analyze the inlet sample for the same parameters as the outlet values and compare the concentrations against the design specifications.

If none of these problems appears, but the outlet water quality is not reaching its requirements, it is very likely that the biological processes in the pre-treatment or in the Tricel plant are not working properly. This can be due to high concentrations of anti-bacterial compounds, for example hypo chloride or detergents that are toxic to the bacteria. In those cases, alternative chemicals need to be found and used. Please contact Tricel for further help.

# 7 Operations and Maintenance

## 7.1 Water Samples

To ensure that the plant performs according to specification, it is important to measure the water quality at the outlet.

To take samples that are as accurate as possible, make sure the sample bottles are clean and the sample is obtained in the last settling zone 10 cm below the surface. Water samples have to be stored cold until they are analyzed, preferably in a freezer or alternatively in a refrigerator. Analysis must be done in a certified laboratory. Samples must be obtained as the first part of the maintenance procedure prior to functionality control.

The oxygen level shall be > 70 % in all chambers and is expected to increase through the system. The pH shall be > 6.5 and <8.5 in all chambers and is expected to fall only a little through the plant.

## 7.2 Confirmation of Connections

Confirm that connections are assembled according to the description in Section 5 - Commissioning.



## 7.3 Inlet pumps



**Prior to performing any maintenance on the pump, un-plug the pump to ensure that it is not accidentally powered during maintenance.**

Assess the pump at each ordinary service. Confirm that the piping is safely fastened to the wall of the pump well.

Pull up one pump at a time and confirm the following:

- Pump is intact and undamaged.
- Impeller is intact.

If the pump or impeller appears damaged or worn, the pump should be replaced. Confirm that all wires are intact and are not affected by weathering. If there is any doubt replace the wires.

## 7.4 Blower



**Prior to servicing the blowers, unplug the blower to ensure blowers do not power up during maintenance.**

### Air Filter

Replace filter at every ordinary service. Clean, rinse and dry the used filter and reuse at next service-interval. If the filter is not re-usable replace with new.

In deserts or other areas with lots of dust and particles in the air, it may be required that filters are replaced more frequently.

### Other mechanical components in blower

For expected lifetime and replacement interval of diaphragm etc., follow blower manufacturers manual.

Confirm that all wires are intact and not affected by weathering. If in doubt replace wires.

## 7.5 Septic Tank

The septic tank should restrain large particles from flowing into the treatment system. If particulate sludge passes through the settling tank, the risk of overloading the treatment unit increases.

The operating septic tank will contain three different layers:

Floating Sludge

Dissolved sewage

Settled sludge

Every settling tank is filled up with sludge when in normal operation, therefore every settling tank needs to be emptied for sludge regularly. This is very important for the function of the biological treatment in the system.

To decide when the settling tank needs to be emptied, use the following guideline:

Confirm that there are no visual signs of primary sludge in the biological treatment tank. If there is sludge in the treatment tank, remove all sludge and fill up with clear water.

Confirm that the depth of the floating sludge in the last chamber of the settling tank is a maximum of 2/3 of the height of the T-pipe at the outlet of the settling tank.

Confirm that the upper level of settled sludge in the last chamber of the settling tank is maximum 500 mm from reaching the outlet pipe.

If these criteria are met, the settling tank needs to be emptied. See Section 7.6 - Emptying the Septic Tank and Sludge Removal.



**Never operate inside a settling tank without full ventilation as there can be high concentrations of hydrogen sulfide and other toxic gases which can cause severe health problems. Never work inside settling tank alone.**



**The Maxus Combi system will not be able to fulfil the outlet requirements if sludge has entered the system. It is very important to remove sludge from the settling tank regularly before the settling tank is filled up.**

## **7.6 Emptying the Septic Tank and Sludge Removal**

Remove the total content of the settling tank either by vacuum or by lowering a sewage pump inside the settling tank. Consult local authorities to enquire information on how to dispose of removed sludge.

When removing the sludge, the settling tank is refilled preferably with clean water.

## **7.7 Control Box**

Relays are expected to have the same lifetimes as the controller and should therefore not be replaced.

## **7.8 Recommended regular maintenance**

1. Check the blower to ensure it is running and there is aeration in the bio zone.
2. Check for any leaks in the piping to and from the system as well as inside the Combi System.
3. Check for any possible damage to the electric cabling to and from the Combi System.
4. All maintenance and changes shall be recorded in a logbook for record-keeping purposes.

## **7.9 Recommended Yearly Maintenance**

1. Sample water for analysis following instruction from section 7.1.
2. Perform the normal inspection as explained in the regular maintenance checks, see above.
3. Check the function of the sludge return, inlet pumps and blowers.
4. Open the air filters on the blowers, check and clean if needs to be cleaned. Replace if necessary.
5. Check the quantity of sludge in the setting tank in accordance with instruction in section 7.5. If necessary, remove sludge.
6. All maintenance and changes shall be recorded and kept in a logbook to allow for better diagnosis in case of problems.

## 7.10 Recommended Spare Parts List for Combi

Component*	Expected Component replacement frequency
Blower diaphragm	3 years
Air filter for blower	1 years
Inlet pump and float switches	7 years
Control unit	10 years
Diffusers	15 years
Solenoid valves	10 years

\*For specific brand and model; see project specific parts list

## 7.11 Operation Without Wastewater for up to 6 Months

If limited or no wastewater is flowing to the Combi system for days or weeks at a time, Tricel recommends continually operating the system as normal. If the load is limited for longer periods, the system will automatically adjust operation to “off-season”-mode, which will reduce the power consumption significantly. The integrated sludge recirculation will keep the biology inside the treatment tank alive for many months, ready to handle untreated wastewater whenever the inlet flow returns to normal level.

For any questions not clarified in this instruction please contact Tricel directly.

## Notes

## Notes

## Notes



Tricel Environmental UK, A trading brand of Dewey Waters Ltd., Tricel Weston, Winterstoke Road,  
Weston-super-Mare, BS24 9AN, United Kingdom  
Tel: 44 (0) 1934 422 311 | Email: [environment@tricel.co.uk](mailto:environment@tricel.co.uk) | [www.tricel.co.uk](http://www.tricel.co.uk)

In accordance with Tricel's normal policy of product development these specifications are subject to change without notice.