



This range of recessed covers is designed to be in-filled with a suitable screed or concrete, and are available in a range of clear opening sizes and feature, as standard, four locking screws and rubber neoprene seal to resist gas egress and water ingress. Gas and airtight under normal atmospheric conditions – suitable for internal applications.

The standard tray depth is a nominal 38 mm, with an overall frame depth of 58 mm.

FACTA AAA full loading capability is achieved when filled with C25 concrete. This accommodates gross laden vehicle weights of 10 tonnes (slow moving pneumatic wheel load 2.5 tonnes).

Comprises mild steel inlay cover and frame, galvanised to BS EN ISO 1461:2009.

Recessed covers rely on a concrete infill to achieve the rated load bearing performance. Use of the appropriate grade of concrete is essential.

KEY FEATURES

- Light to medium duty (10 tonne GLWV, FACTA AAA)
- Mild steel inlay cover and frame
- Double-sealed and locking
- Galvanised to BS EN 1461:2009

SEALING

- A** Cover seal
- B** Neoprene seal
- C** Frame seal

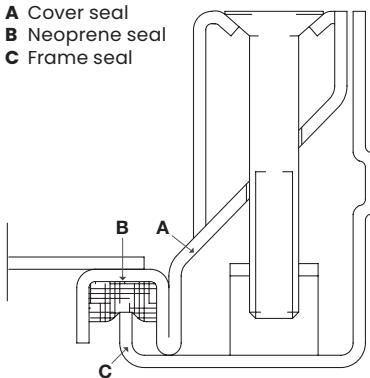

DIMENSIONS mm

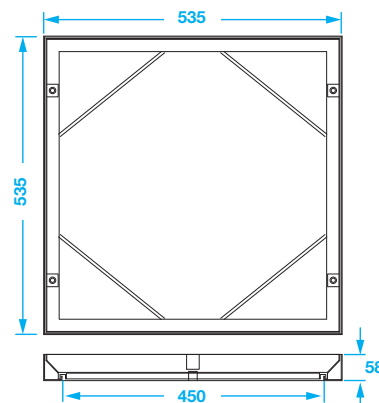

LIFTING METHOD

