

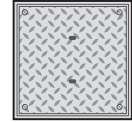

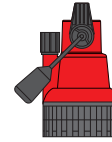

SYSTEM OVERVIEW



One powerful free-standing automatic pumps

Access cover, solid top, locking, galvanised steel, FACTA AA

 1½" Class E PVC pipework

 1½" Class E PVC discharge

 110 mm inlet

 50 mm cable duct

A fully automatic wastewater pumping system suitable for pumping surface and/or groundwater to a higher level when gravity drainage is not possible and/or economical to install.

It features a powerful submersible pump for high head (up to 12 m) and flow (up to 4 l/s) applications.

The system provides up to 165 litre storage capacity depending inlet depth. It can accept waste from car parks, car washes, floor areas, down pipes, cavity membrane systems or similar.

The system consists of a polyethylene tank, a powerful automatic wastewater submersible pump and a solid top, locking, galvanised steel access cover (FACTA AA) (#106988). It discharges to solvent welded 1½" Class E PVC. Optional discharge reducer kits can increase external discharge diameter to 1½" or 2" to reduce friction loss.

It is easy to install as inlets can be positioned to your site's requirements. Inlet information to be supplied at time of order, or can be drilled on site.

For groundwater and surface water applications where inflow cannot be controlled, twin pump systems complete with a high level alarm and battery backup system should be used, in accordance with BS 8102:2022 and PCA Guidelines. High level alarms and battery backup systems can be purchased to your specification.

KEY FEATURES

- Powerful vortex pump for high head and flow
- Up to 165 litres storage capacity
- Compact chamber for limited space installations
- Ideal for an extension, outbuilding, basement or similar
- 450 mm x 450 mm clear opening
- Variable inlet positions to suit site
- A range of battery backup systems are available
- A range of alarms and remote alerts are available
- Quick and simple to install

WASTE TYPE



Grey



Ground



Surface



Storm

This system is not suitable for receiving foul waste. Contact our Sales Team for advice on a suitable foul water packaged pumping stations for your property.

RECOMMENDED ACCESSORIES

AquaSafe Alarm Sump



High level alarm alert
HLA recorded alert
Service due alert
Volt-free contacts
Alarm battery backup

106993

Inlay access cover 450 x 450 mm

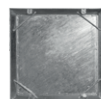

106986

Additional inlet

110 mm 50 mm



107034

107035

EXAMPLE INSTALLATION

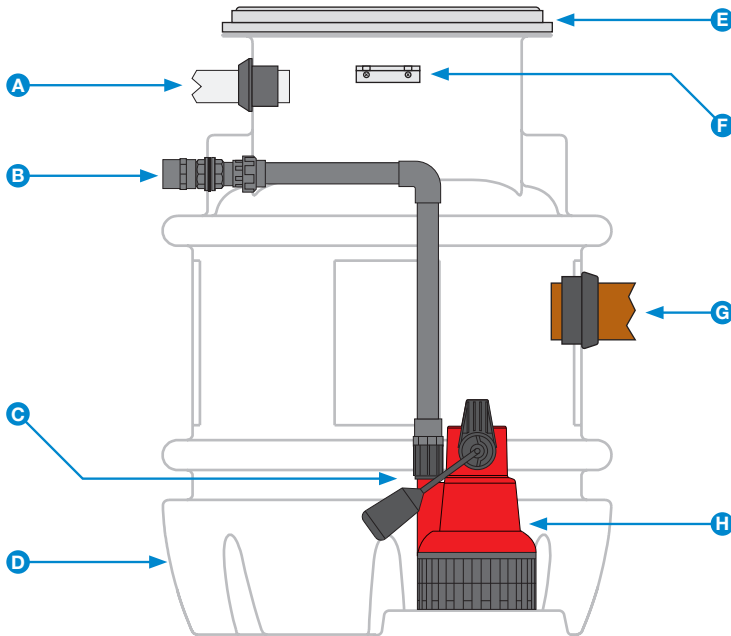

- A 50 mm cable duct positioned to site requirements.
- B Plain female discharge for solvent welding to 1½" Class E PVC.
- C Non-return valve.
- D Structurally-reinforced virgin tank-grade polyethylene chamber.
- E Galvanised steel, solid top, locking, access cover, FACTA AA.
- F Float bracket for optional high level alarm mini float.
- G 110 mm inlet positioned to site requirements (additional inlets available).
- H Powerful 240 V automatic submersible pump.

CHAMBER DIMENSIONS

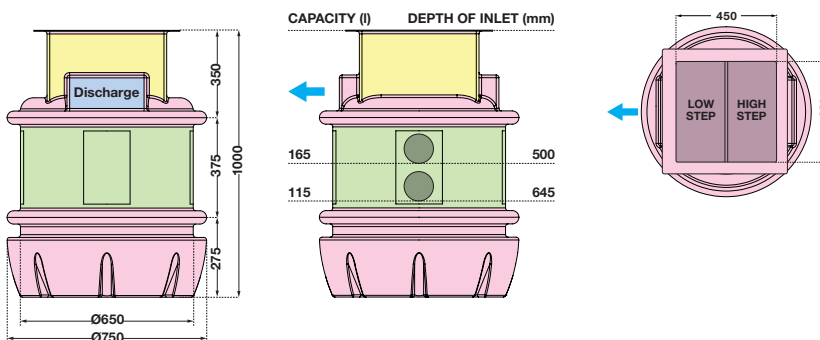

Permitted connection positions

Capacities indicative from lowest inlet invert.

Discharge only	Inlet location allowed	Cable ducts and vents only	No drilling allowed
----------------	------------------------	----------------------------	---------------------

PUMP SPECIFICATIONS

Number of pumps	One
Impellor type	Vortex
Control	Automatic
Power supply	230 VAC
Rated current	4.9 A
Motor rating (P2)	500 W
Discharge size	1½"
Free passage	10 mm
Max. vertical output	12.5 m
Max. flow rate	4.0 l/s
Max liquid temp.	<40 °C
Cable length	5 m
Weight	6.9 kg

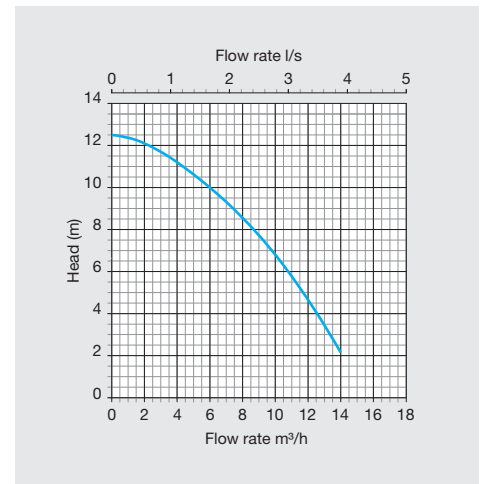

CHAMBER SPECIFICATIONS

Internal pipework	1½" OD Class E PVC
Discharge pipework	1½" OD Class E PVC
Lifting eyes	No
Max. storage capacity	165 litres
Chamber material	Tank-grade polyethylene
Dimensions (Ø x H)	750 x 1000 mm
Clear opening	450 x 450 mm

In accordance with Tricel's normal policy of product development these specifications are subject to change without notice. Tricel (Killarney) Unlimited Company trading as Tricel.