

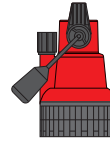

SYSTEM OVERVIEW

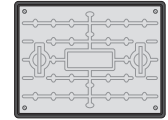

One powerful free-standing automatic pump



Access cover, solid top, locking, galvanised steel, PP frame, FACTA A



1 1/4" Class E PVC pipework



110 mm inlet



1 1/4" Class E PVC discharge



50 mm cable duct



1 1/4" brass valves



110 mm vent

A fully automatic wastewater pumping system suitable for pumping surface and/or groundwater to a higher level when gravity drainage is not possible and/or economical to install.

The system provides up to 325 litre storage capacity depending on inlet depth. It can accept waste from car parks, car washes, floor areas, down pipes, cavity membrane systems or similar.

The system consists of a polyethylene tank, Class E PVC internal pipework with brass valves, one powerful automatic wastewater submersible pump and a solid top, locking, galvanised steel access cover (FACTA A).

It discharges to solvent welded 1 1/4" Class E PVC. Optional discharge reducer kits can increase external discharge diameter to 1 1/2" or 2" to reduce friction loss. Compression fittings are also available for discharging to MDPE pipework.

It is easy to install as inlets can be positioned to your site's requirements. Inlet information to be supplied at time of order, or can be drilled on site.

For groundwater and surface water applications where inflow cannot be controlled, twin pump systems complete with a high level alarm and battery backup system should be used, in accordance with BS 8102:2022 and PCA Guidelines. High level alarms and battery backup systems can be purchased to your specification.

KEY FEATURES

- Powerful vortex pump for high head and flow
- Up to 325 litres storage capacity
- Compact chamber for limited space installations
- Ideal for an extension, outbuilding, basement or similar
- 600 mm x 450 mm clear opening
- Variable inlet positions to suit site
- A range of battery backup systems are available
- A range of alarms and remote alerts are available
- Quick and simple to install

WASTE TYPE



Grey



Ground



Surface



Storm

This system is not suitable for receiving foul waste. Contact our Sales Team for advice on a suitable foul water packaged pumping stations for your property.

RECOMMENDED ACCESSORIES

AquaSafe Alarm Sump



High level alarm alert
HLA recorded alert
Service due alert
Volt-free contacts
Alarm battery backup

106993

Inlay access cover 600 x 450 mm

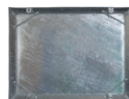

106985

Additional inlet

110 mm 50 mm



107034



107035

EXAMPLE INSTALLATION

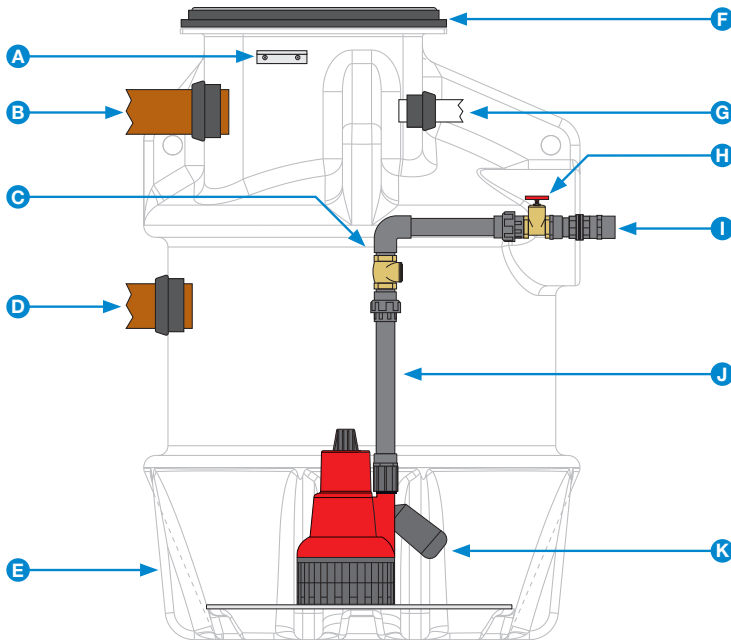

- A Float bracket for optional high level alarm mini float.
- B 110 mm inlet positioned to site requirements.
- C Brass swing check valve.
- D 110 mm inlet positioned to site requirements (additional inlets available).
- E Structurally-reinforced virgin tank-grade polyethylene chamber.
- F Galvanised steel, solid top, locking, access cover, PP frame, FACTA A.
- G 50 mm cable duct positioned to site requirements.
- H Brass gate valve.
- I 1 1/4" Class E PVC plain female discharge for solvent welding to high pressure PVC.
- J 1 1/4" Class E PVC pipework.
- K Powerful 240 V automatic submersible pump.

PUMP SPECIFICATIONS

Number of pumps	One
Impellor type	Vortex
Control	Automatic
Power supply	230 VAC
Rated current	4.9 A
Motor rating (P2)	500 W
Discharge size	1 1/4"
Free passage	10 mm
Max. vertical output	12.5 m
Max. flow rate	4.0 l/s
Max liquid temp.	<40 °C
Cable length	5 m
Weight	6.9 kg

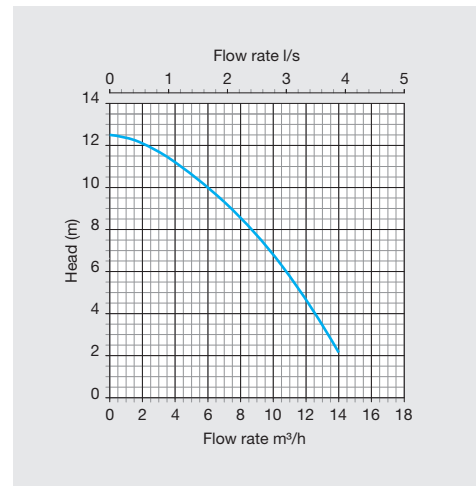

CHAMBER DIMENSIONS

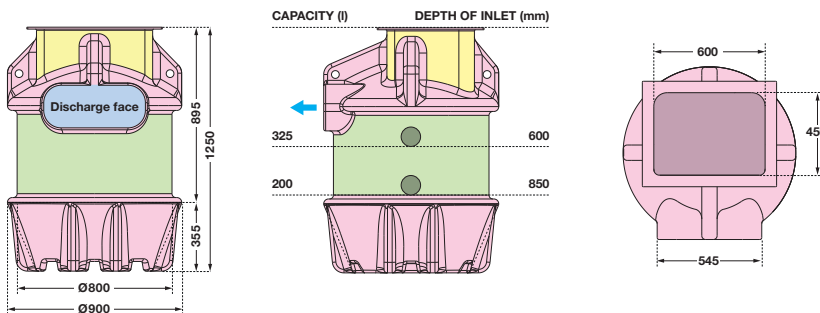

CHAMBER SPECIFICATIONS

Internal pipework	1 1/4" OD Class E PVC
Discharge pipework	1 1/4" OD Class E PVC
Lifting eyes	4 no
Max. storage capacity	325 litres
Chamber material	Tank-grade polyethylene
Dimensions (Ø x H)	900 x 1250 mm
Clear opening	600 x 450 mm

Permitted connection positions

Capacities indicative from lowest inlet invert.



In accordance with Tricel's normal policy of product development these specifications are subject to change without notice. Tricel (Killarney) Unlimited Company trading as Tricel.