

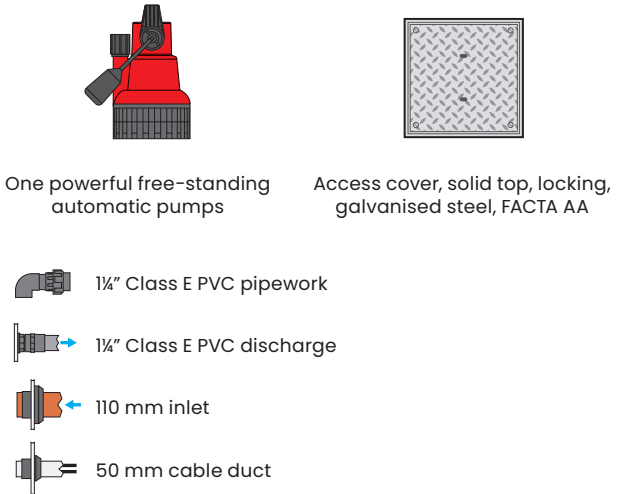

## SYSTEM OVERVIEW



A fully automatic wastewater pumping system suitable for pumping surface and/or groundwater to a higher level when gravity drainage is not possible and/or economical to install.

It features a powerful submersible pump for high head (up to 12 m) and flow (up to 4 l/s) applications.

The system provides up to 65 litre storage capacity depending inlet depth. It can accept waste from car parks, car washes, floor areas, down pipes, cavity membrane systems or similar.

The system consists of a polyethylene tank, a powerful automatic wastewater submersible pump and a solid top, locking, galvanised steel access cover (FACTA AA). It discharges to solvent welded 1 1/4" Class E PVC. Optional discharge reducer kits can increase external discharge diameter to 1 1/2" or 2" to reduce friction loss.

It is easy to install as inlets can be positioned to your site's requirements. Inlet information to be supplied at time of order, or can be drilled on site.

**For groundwater and surface water applications where inflow cannot be controlled, twin pump systems complete with a high level alarm and battery backup system should be used, in accordance with BS 8102:2022 and PCA Guidelines. High level alarms and battery backup systems can be purchased to your specification.**

## KEY FEATURES

- Powerful vortex pump for high head and flow
- Up to 65 litres storage capacity
- Compact chamber for limited space installations
- Ideal for an extension, outbuilding, basement or similar
- 350 mm x 350 mm clear opening
- Variable inlet positions to suit site
- A range of battery backup systems are available
- A range of alarms and remote alerts are available
- Quick and simple to install

## WASTE TYPE



**This system is not suitable for receiving foul waste. Contact our Sales Team for advice on a suitable foul water packaged pumping stations for your property.**

## RECOMMENDED ACCESSORIES

**AquaSafe Alarm Sump**



High level alarm alert  
HLA recorded alert  
Service due alert  
Volt-free contacts  
Alarm battery backup

106993

**Inlay access cover  
600 x 450 mm**



106985

**Additional inlet**

110 mm    50 mm



107034    107035

## EXAMPLE INSTALLATION

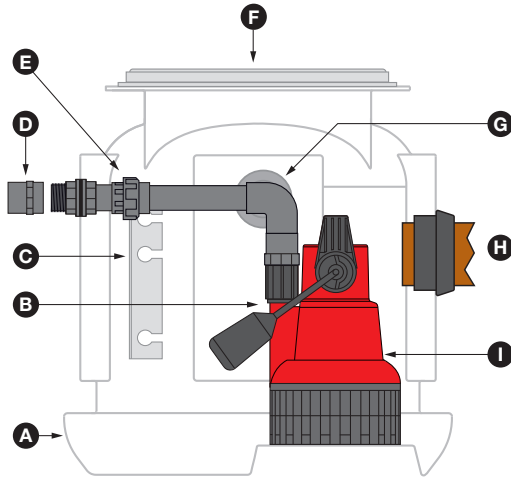

- A Structurally-reinforced virgin tank-grade polyethylene chamber.
- B Non-return valve.
- C Float bracket for optional high level alarm mini float.
- D 1½" Class E PVC plain female discharge for solvent welding to high pressure PVC.
- E Socket union for simple pump removal during servicing.
- F Galvanised steel, solid top, locking, access cover, FACTA AA.
- G 50 mm cable duct positioned to site requirements.
- H 110 mm inlet positioned to site requirements (additional inlets available).
- I Powerful automatic 240 V submersible pump.

## CHAMBER DIMENSIONS

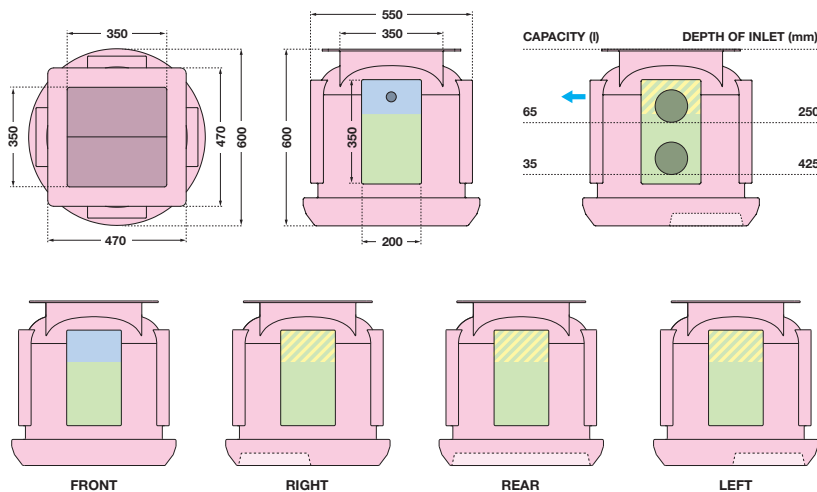

### Permitted connection positions

Capacities indicative from lowest inlet invert.



## PUMP SPECIFICATIONS

Number of pumps	One
Impellor type	Vortex
Control	Automatic
Power supply	230 VAC
Rated current	4.9 A
Motor rating (P2)	500 W
Discharge size	1½"
Free passage	10 mm
Max. vertical output	12.5 m
Max. flow rate	4.0 l/s
Max liquid temp.	<40 °C
Cable length	5 m
Weight	6.9 kg

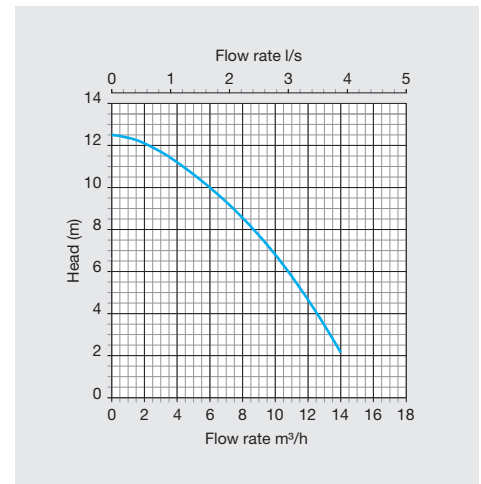

## CHAMBER SPECIFICATIONS

Internal pipework	1½" OD Class E PVC
Discharge pipework	1½" OD Class E PVC
Lifting eyes	No
Max. storage capacity	65 litres
Chamber material	Tank-grade polyethylene
Dimensions (Ø x H)	600 x 600 mm
Clear opening	350 x 350 mm

In accordance with Tricel's normal policy of product development these specifications are subject to change without notice. Tricel (Killarney) Unlimited Company trading as Tricel.