

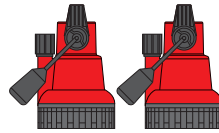

SYSTEM OVERVIEW

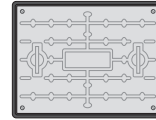

Two free-standing automatic pumps



Access cover, solid top, locking, galvanised steel, PP frame, FACTA A

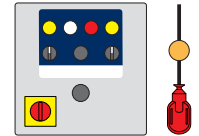

Timer control panel with high level alarm and volt-free contact



1/4" Class E PVC pipework



1/4" Class E PVC discharge



1/4" brass valves



110 mm inlet



50 mm cable duct



110 mm vent

A fully automatic wastewater pumping system suitable for pumping surface and/or groundwater to a higher level when gravity drainage is not possible and/or economical to install.

The system provides up to 575 litre storage capacity depending on inlet depth. It can accept waste from car parks, car washes, floor areas, down pipes, cavity membrane systems or similar.

The system consists of a polyethylene tank, Class E PVC internal pipework with brass valves, two automatic wastewater submersible pumps and a solid top, locking, galvanised steel access cover (FACTA A). A control panel balances the wear between the two pumps, and provides a high level alarm and volt-free contacts for remote monitoring.

It discharges to solvent welded 1/4" Class E PVC. Optional discharge reducer kits can increase external discharge diameter to 1/2" or 2" to reduce friction loss. Compression fittings are also available for discharging to MDPE pipework.

It is easy to install as inlets can be positioned to your site's requirements. Inlet information to be supplied at time of order, or can be drilled on site.

For groundwater and surface water applications where inflow cannot be controlled, a battery backup system should be used, in accordance with BS 8102:2022 and PCA Guidelines. Battery backup systems can be purchased to your specification.

KEY FEATURES

- Vortex impellor for high flow rates
- Twin pumps for backup if one of the pumps fail
- Control panel for timed changeover, high level alarm and volt-free contacts
- Up to 575 litres storage capacity
- Compact chamber for limited space installations
- Ideal for an extension, outbuilding, basement or similar
- 600 mm x 450 mm clear opening
- Variable inlet positions to suit site
- A range of battery backup systems are available
- A range of alarms and remote alerts are available
- Quick and simple to install

WASTE TYPE



Grey



Ground



Surface



Storm

This system is not suitable for receiving foul waste. Contact our Sales Team for advice on a suitable foul water packaged pumping stations for your property.

RECOMMENDED ACCESSORIES

Inlay access cover
600 x 450 mm

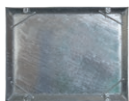

106985

Additional inlet

110 mm 50 mm



107034

107035

EXAMPLE INSTALLATION

Chamber illustrated is 800 mm x 1250 mm.

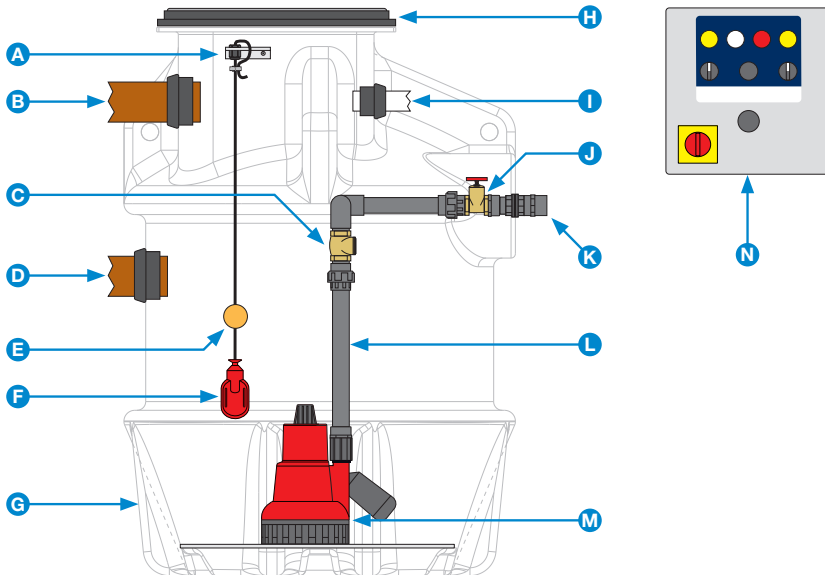

- A Float bracket for high level alarm float.
- B 110 mm vent duct.
- C Brass swing check valve.
- D 110 mm inlet positioned to site requirements (additional inlets available).
- E Counterweight
- F High level alarm float
- G Structurally-reinforced virgin tank-grade polyethylene chamber.
- H Galvanised steel, solid top, locking, access cover, PP frame, FACTA A.
- I 50 mm cable duct positioned to site requirements.
- J Brass gate valve.
- K 1½" Class E PVC plain female discharge for solvent welding to high pressure PVC.
- L 1½" Class E PVC pipework.
- M 240 V automatic submersible pump.
- N Timer control panel with high level alarm and volt-free contact

PUMP SPECIFICATIONS (PER PUMP)

Number of pumps	Two
Impellor type	Vortex
Control	Automatic
Power supply	230 VAC
Rated current	1.9 A
Motor rating (P2)	180 W
Discharge size	1½"
Free passage	10 mm
Max. vertical output	6.8 m
Max. flow rate	2.9 l/s
Max liquid temp.	<40 °C
Cable length	5 m
Weight	5.2 kg

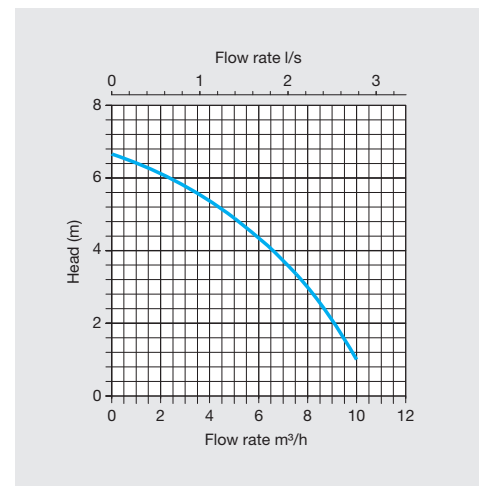

CHAMBER DIMENSIONS

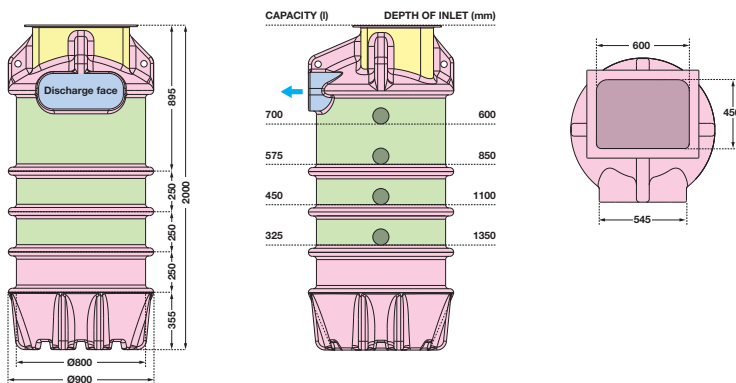

CHAMBER SPECIFICATIONS

Internal pipework	1½" OD Class E PVC
Discharge pipework	1½" OD Class E PVC
Lifting eyes	4 no
Max. storage capacity	700 litres
Chamber material	Tank-grade polyethylene
Dimensions (Ø x H)	900 x 2000 mm
Clear opening	600 x 450 mm

Permitted connection positions

Capacities indicative from lowest inlet invert.

Discharge only	Inlet location allowed	Cable ducts and vents only	No drilling allowed
----------------	------------------------	----------------------------	---------------------

In accordance with Tricel's normal policy of product development these specifications are subject to change without notice. Tricel (Killarney) Unlimited Company trading as Tricel.