

## SYSTEM OVERVIEW

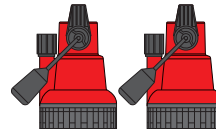

Two free-standing automatic pumps

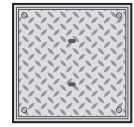

Access cover, solid top, locking, galvanised steel, FACTA AA

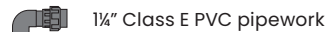

1/4" Class E PVC pipework

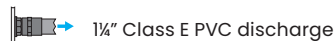

1/4" Class E PVC discharge



110 mm inlet

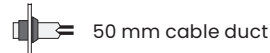

50 mm cable duct

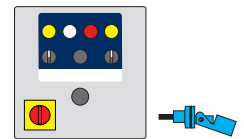

Timer control panel with high level alarm and volt-free contact

A fully automatic wastewater pumping system suitable for pumping surface and/or groundwater to a higher level when gravity drainage is not possible and/or economical to install.

The system provides up to 65 litre storage capacity depending inlet depth. It can accept waste from car parks, car washes, floor areas, down pipes, cavity membrane systems or similar.

The system consists of a polyethylene tank, two automatic wastewater submersible pumps and a solid top, locking, galvanised steel access cover (FACTA AA). A control panel balances the wear between the two pumps, and provides a high level alarm and volt-free contacts for remote monitoring.

It discharges to solvent welded 1/4" Class E PVC. Optional discharge reducer kits can increase external discharge diameter to 1/2" or 2" to reduce friction loss.

It is easy to install as inlets can be positioned to your site's requirements. Inlet information to be supplied at time of order, or can be drilled on site.

**For groundwater and surface water applications where inflow cannot be controlled a battery backup system should be used, in accordance with BS 8102:2022 and PCA Guidelines. Battery backup systems can be purchased to your specification.**

## KEY FEATURES

- Vortex impellor for high flow rates
- Twin pumps for backup if one of the pumps fail
- Control panel for timed changeover, high level alarm and volt-free contacts
- Up to 65 litres storage capacity
- Compact chamber for limited space installations
- Ideal for an extension, outbuilding, basement or similar
- 350 mm x 350 mm clear opening
- Variable inlet positions to suit site
- A range of battery backup systems are available
- A range of alarms and remote alerts are available
- Quick and simple to install

## WASTE TYPE



Grey



Ground



Surface



Storm

**This system is not suitable for receiving foul waste. Contact our Sales Team for advice on a suitable foul water packaged pumping stations for your property.**

## RECOMMENDED ACCESSORIES

**Inlay access cover**  
450 x 450 mm

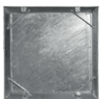

106986

**Additional inlet**

110 mm    50 mm



107034

107035

## EXAMPLE INSTALLATION

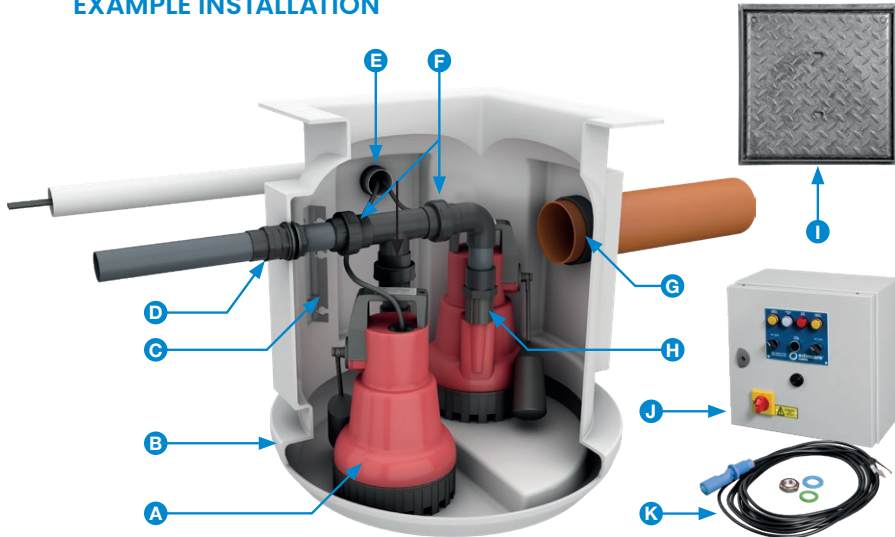

- A Automatic 240 V submersible pump.
- B Structurally-reinforced virgin tank-grade polyethylene chamber.
- C Float bracket for optional high level alarm mini float.
- D 1½" Class E PVC plain female discharge for solvent welding to high pressure PVC.
- E 50 mm cable duct positioned to site requirements.
- F Socket union for simple pump removal during servicing.
- G 110 mm inlet positioned to site requirements (additional inlets available).
- H Non-return valve.
- I Galvanised steel, solid top, locking, access cover, FACTA AA.
- J Timer control panel with high level alarm and volt-free contact.
- K High level alarm mini float switch.

## CHAMBER DIMENSIONS

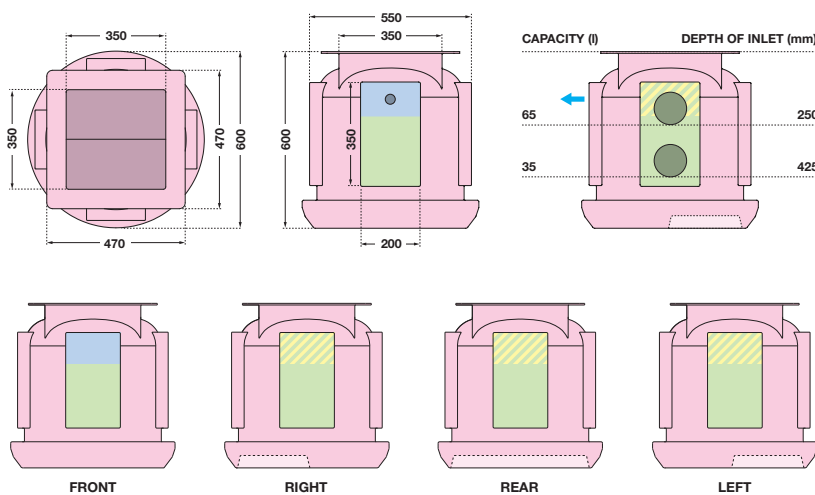

### Permitted connection positions

Capacities indicative from lowest inlet invert.

Discharge only	Inlet location allowed	Cable ducts and vents only	No drilling allowed
----------------	------------------------	----------------------------	---------------------

## PUMP SPECIFICATIONS (PER PUMP)

Number of pumps	Two
Impellor type	Vortex
Control	Automatic
Power supply	230 VAC
Rated current	1.9 A
Motor rating (P2)	180 W
Discharge size	1½"
Free passage	10 mm
Max. vertical output	6.8 m
Max. flow rate	2.9 l/s
Max liquid temp.	<40 °C
Cable length	5 m
Weight	5.2 kg

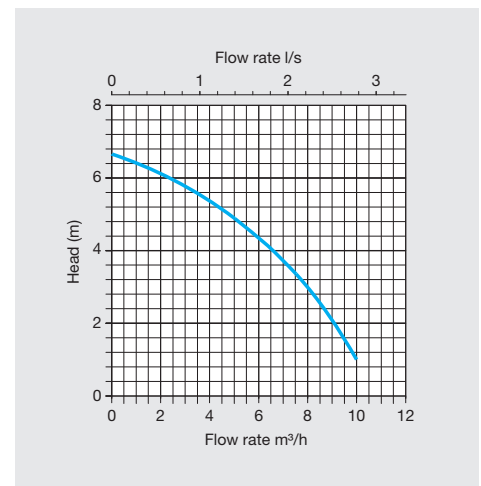

## CHAMBER SPECIFICATIONS

Internal pipework	1½" OD Class E PVC
Discharge pipework	1½" OD Class E PVC
Lifting eyes	No
Max. storage capacity	65 litres
Chamber material	Tank-grade polyethylene
Dimensions (Ø x H)	600 x 600 mm
Clear opening	350 x 350 mm

In accordance with Tricel's normal policy of product development these specifications are subject to change without notice. Tricel (Killarney) Unlimited Company trading as Tricel.