

SYSTEM OVERVIEW

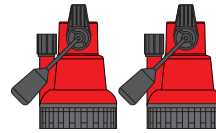

Two free-standing automatic pumps

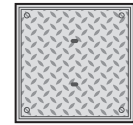

Access cover, solid top, locking, galvanised steel, FACTA AA

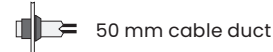
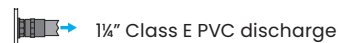

A fully automatic wastewater pumping system suitable for pumping surface and/or groundwater to a higher level when gravity drainage is not possible and/or economical to install.

The system provides up to 65 litre storage capacity depending inlet depth. It can accept waste from car parks, car washes, floor areas, down pipes, cavity membrane systems or similar.

The system consists of a polyethylene tank, two automatic wastewater submersible pumps and a solid top, locking, galvanised steel access cover (FACTA AA).

It discharges to solvent welded 1½" Class E PVC. Optional discharge reducer kits can increase external discharge diameter to 1½" or 2" to reduce friction loss.

It is easy to install as inlets can be positioned to your site's requirements. Inlet information to be supplied at time of order, or can be drilled on site.

For groundwater and surface water applications where inflow cannot be controlled, a high level alarm and battery backup system should be used, in accordance with BS 8102:2022 and PCA Guidelines. High level alarms and battery backup systems can be purchased to your specification.

KEY FEATURES

- Vortex impellor for high flow rates
- Twin pumps for backup if one of the pumps fail
- Up to 65 litres storage capacity
- Compact chamber for limited space installations
- Ideal for an extension, outbuilding, basement or similar
- 350 mm x 350 mm clear opening
- Variable inlet positions to suit site
- A range of battery backup systems are available
- A range of alarms and remote alerts are available
- Quick and simple to install

WASTE TYPE



Grey



Ground



Surface



Storm

This system is not suitable for receiving foul waste. Contact our Sales Team for advice on a suitable foul water packaged pumping stations for your property.

RECOMMENDED ACCESSORIES

AquaSafe Alarm Sump



High level alarm alert
HLA recorded alert
Service due alert
Volt-free contacts
Alarm battery backup

106993

Inlay access cover 600 x 450 mm



106985

Additional inlet

110 mm 50 mm



107034 107035

EXAMPLE INSTALLATION

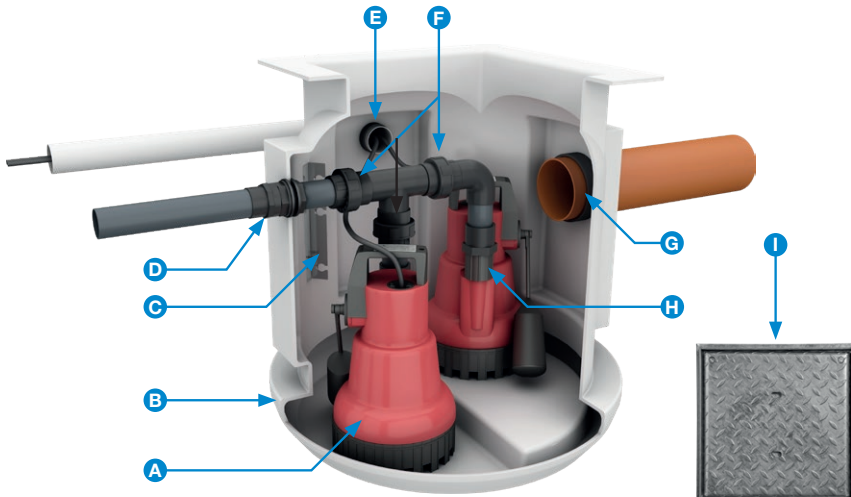

- A Automatic 240 V submersible pump.
- B Structurally-reinforced virgin tank-grade polyethylene chamber.
- C Float bracket for optional high level alarm mini float.
- D 1½" Class E PVC plain female discharge for solvent welding to high pressure PVC.
- E 50 mm cable duct positioned to site requirements.
- F Socket union for simple pump removal during servicing.
- G 110 mm inlet positioned to site requirements (additional inlets available).
- H Non-return valve.
- I Galvanised steel, solid top, locking, access cover, FACTA AA.

CHAMBER DIMENSIONS

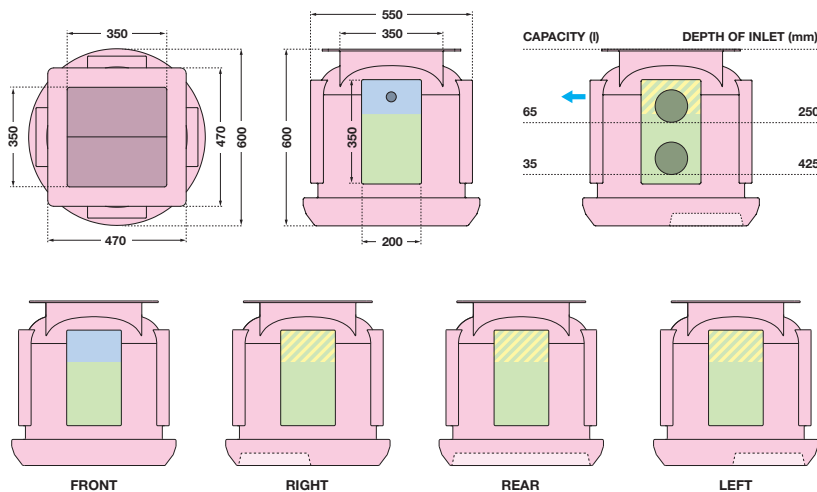

Permitted connection positions

Capacities indicative from lowest inlet invert.

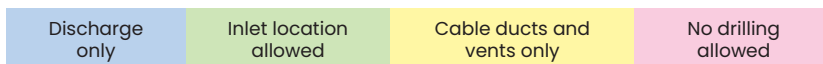

PUMP SPECIFICATIONS (PER PUMP)

Number of pumps	Two
Impellor type	Vortex
Control	Automatic
Power supply	230 VAC
Rated current	1.9 A
Motor rating (P2)	180 W
Discharge size	1½"
Free passage	10 mm
Max. vertical output	6.8 m
Max. flow rate	2.9 l/s
Max liquid temp.	<40 °C
Cable length	5 m
Weight	5.2 kg

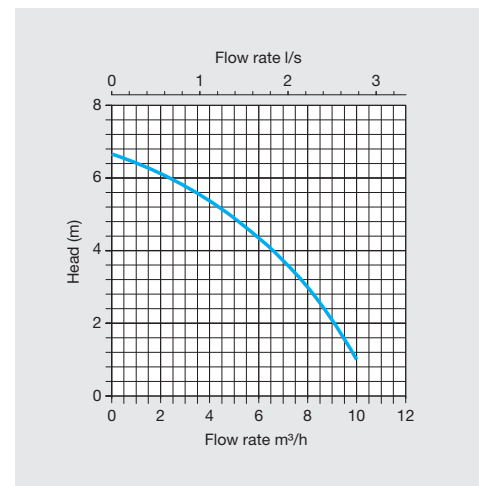

CHAMBER SPECIFICATIONS

Internal pipework	1½" OD Class E PVC
Discharge pipework	1½" OD Class E PVC
Lifting eyes	No
Max. storage capacity	65 litres
Chamber material	Tank-grade polyethylene
Dimensions (Ø x H)	600 x 600 mm
Clear opening	350 x 350 mm