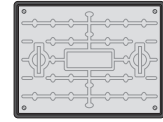

Illustration shows FoulMax 1250

SYSTEM OVERVIEW



One stainless steel free-standing automatic pump



Access cover, solid top, locking, galvanised steel, PP frame, FACTA A

- 2" Class E PVC pipework
- 2" brass valves
- 63 mm MDPE discharge

- 110 mm inlet
- 110 mm cable duct
- 110 mm vent

Pumps by



PRODUCT SUMMARY

- Suitable for foul and grey water
- Structurally-reinforced tank-grade HDPE chamber
- One stainless steel free-standing automatic pump
- Vortex impellor for high flow rates
- 600 mm x 450 mm chamber clear opening
- Access cover, 600 x 450 mm clear opening, locking, galvanised steel top with polypropylene frame, single seal, FACTA A (pedestrian duty)
- Inlets, vent and cable duct can be drilled on site

PUMP SPECIFICATIONS

Rated current	5.9 A
P2 motor rating	750 W
RCBO Type-C rating	10 A
Max. head	7.7 m
Max. flow rate	6.7 l/s
Discharge size	2"
Free passage	50 mm
Pump cable length	10 m

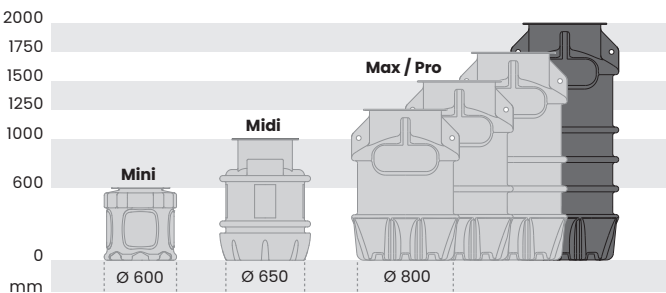
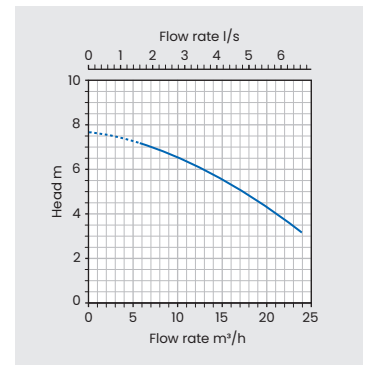

Distance pumped at 1.8 l/s (63 mm OD MDPE)

Static head m	Distance m	Static head m	Distance m
2.0	536	6.0	268
3.0	469	7.0	201
4.0	402	8.0	134
5.0	335	9.0	67

Static head is measured from the pump not chamber discharge.

In accordance with Tricel's normal policy of product development these specifications are subject to change without notice. Tricel (Killarney) Unlimited Company trading as Tricel.

KEY FEATURES

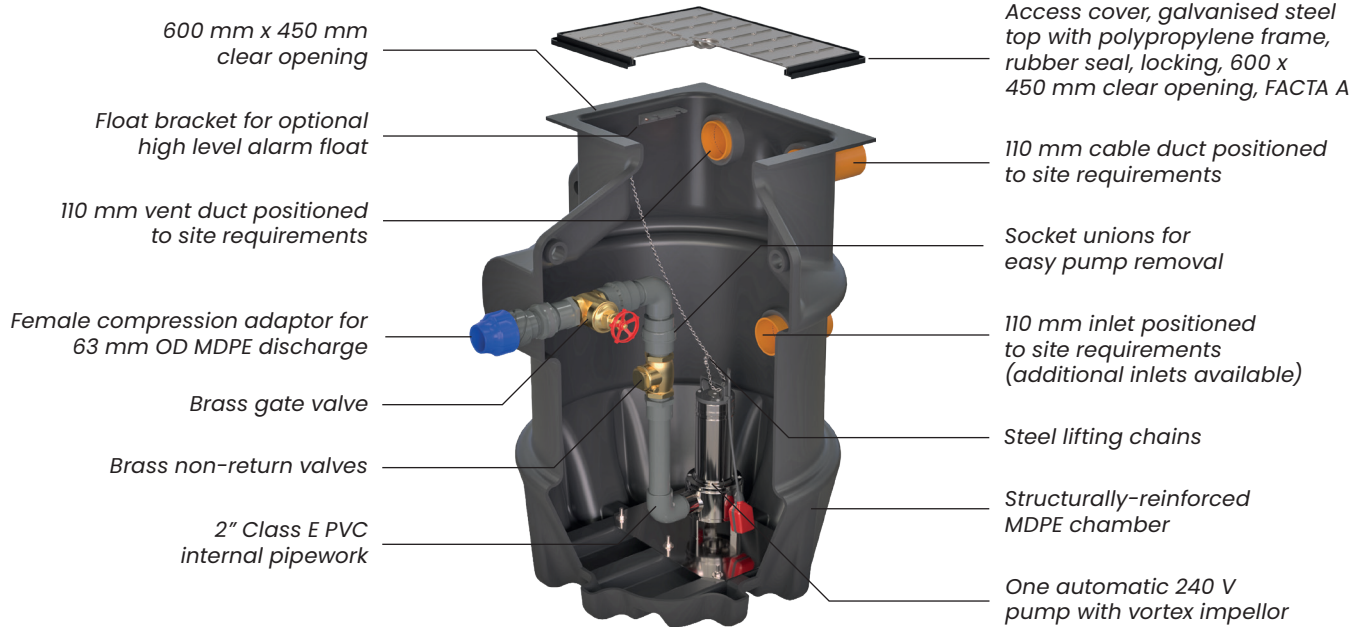
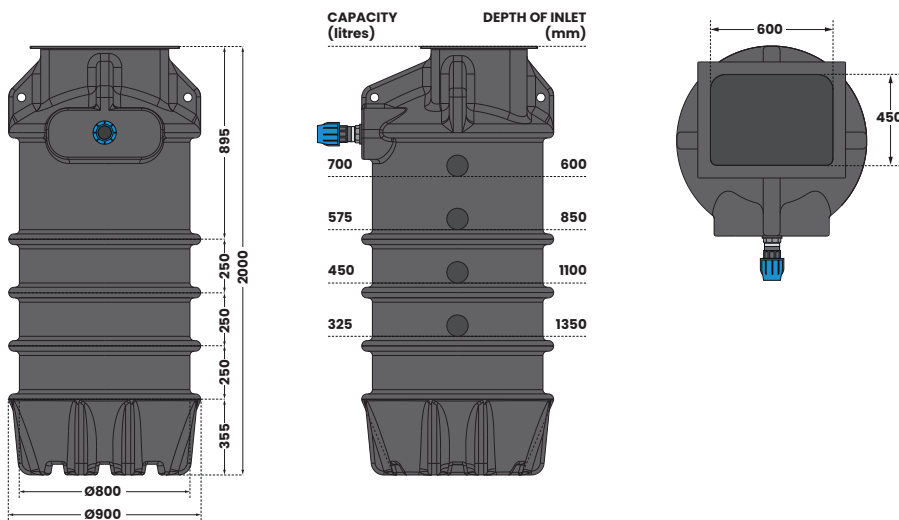

Illustration shows FoulMax 1250

DIMENSIONS



Internal pipework	2" OD Class E PVC
Discharge pipework	2" OD Class E PVC
Chamber material	Tank-grade HDPE
Lifting eyes	Yes

Indicative capacity from inlet invert

RECOMMENDED ACCESSORIES

Tricel AquaSafe Alarm c/w Sump Float Kit



High level alarm alert
HLA recorded alert
Service due alert
Volt-free contacts
Alarm battery backup

106993

Inlay access cover 600 x 450 mm

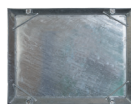

106985

Additional connections

110 mm 50 mm



107034

107035