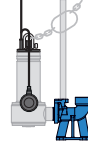

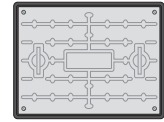

Illustration shows FoulPro 1250

## SYSTEM OVERVIEW



One stainless steel pedestal mounted automatic pumps



Access cover, solid top, locking, galvanised steel, PP frame, FACTA A

2" Class E PVC pipework

2" brass valves

63 mm MDPE discharge

AquaSafe Alarm

110 mm inlet

110 mm cable duct

110 mm vent

Pumps by  
**xylem**  
Let's Solve Water

## PRODUCT SUMMARY

- Suitable for foul and grey water
- Structurally-reinforced tank-grade HDPE chamber
- One stainless steel pedestal mounted automatic pump
- Vortex impellor for high flow rates
- 600 mm x 450 mm chamber clear opening
- Access cover, 600 x 450 mm clear opening, locking, galvanised steel top with polypropylene frame, single seal, FACTA A (pedestrian duty)
- Inlets, vent and cable duct can be drilled on site

## PUMP SPECIFICATIONS

Rated current	5.9 A
P2 motor rating	750 W
RCBO Type-C rating	10 A
Max. head	7.7 m
Max. flow rate	6.7 l/s
Discharge size	2"
Free passage	50 mm
Pump cable length	10 m

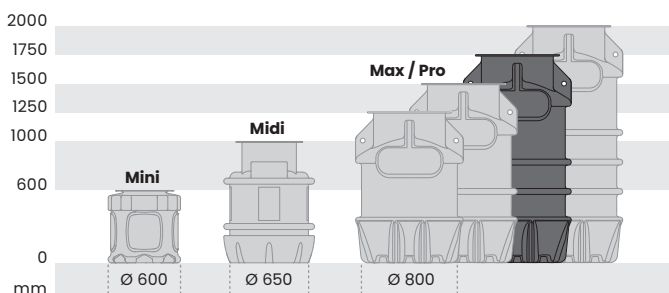
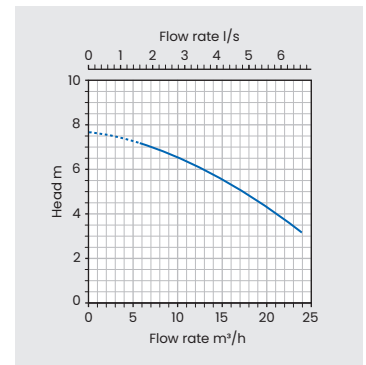

## Distance pumped at 1.8 l/s (63 mm OD MDPE)

Static head m	Distance m	Static head m	Distance m
2.0	175	5.0	70
3.0	140	6.0	35
4.0	105	7.0	0

Static head is measured from the pump not chamber discharge.

In accordance with Tricel's normal policy of product development these specifications are subject to change without notice. Tricel (Killarney) Unlimited Company trading as Tricel.

## KEY FEATURES

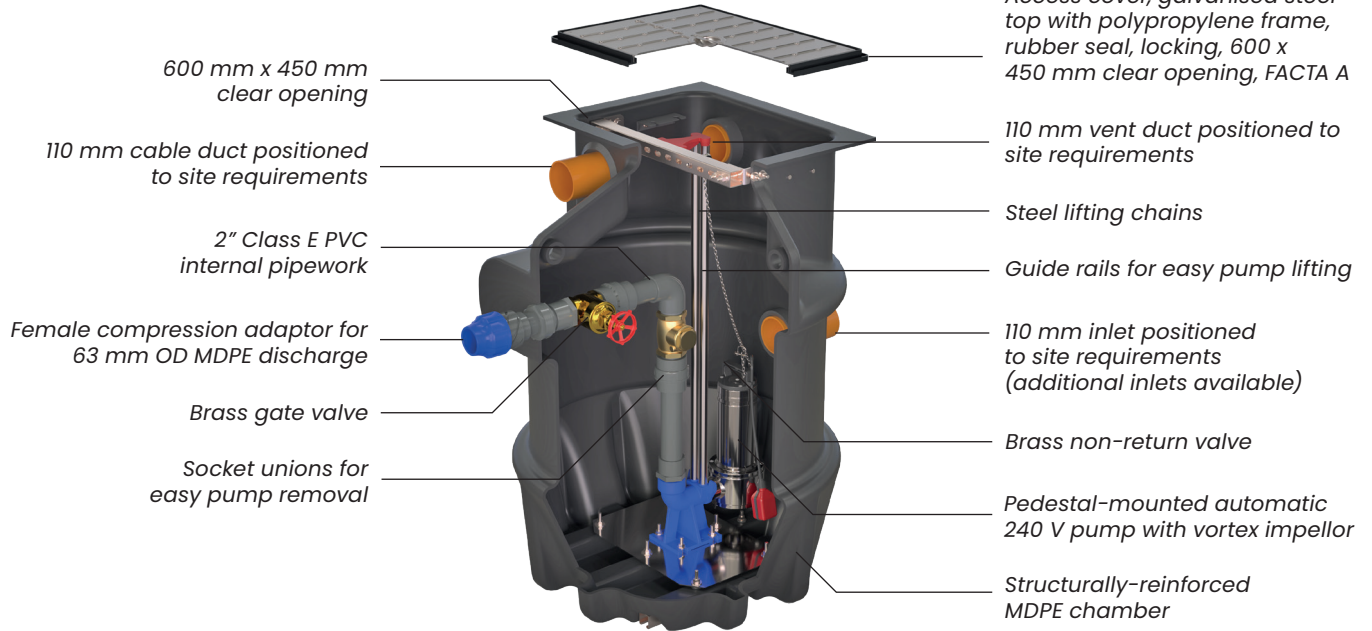
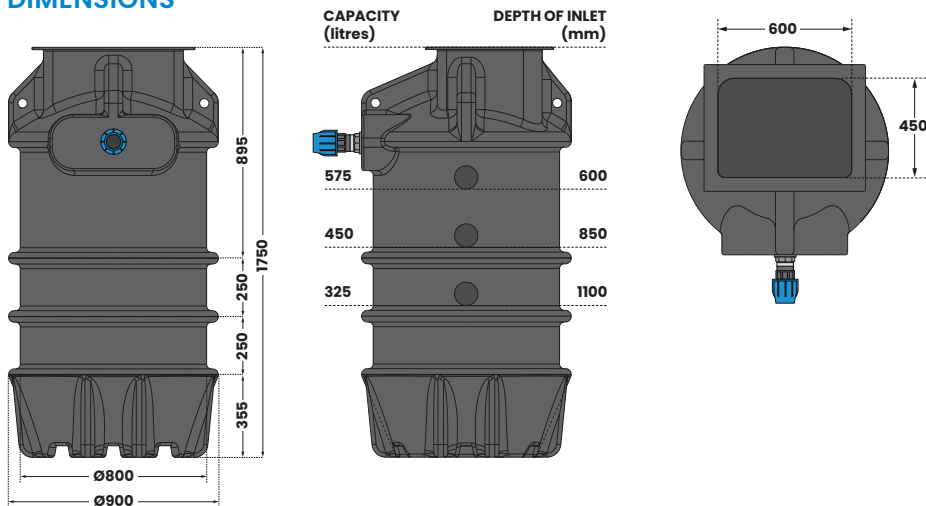

Illustration shows FoulPro 1250

## DIMENSIONS



Internal pipework	2" OD Class E PVC
Discharge pipework	2" OD Class E PVC
Chamber material	Tank-grade HDPE
Lifting eyes	Yes

Indicative capacity from inlet invert

## RECOMMENDED ACCESSORIES

**Inlay access cover**  
600 x 450 mm

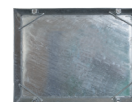

106985

**Additional connections**

110 mm    50 mm



107034

107035