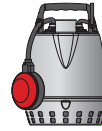
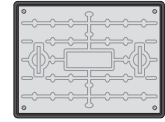

Illustration shows HydroMax 1250.

## SYSTEM OVERVIEW



One stainless steel free-standing automatic pumps



Access cover, solid top, locking, galvanised steel, PP frame, FACTA A



1 1/4" Class E PVC pipework



1 1/4" Class E PVC discharge



1 1/4" brass valves



110 mm inlet



50 mm cable duct



110 mm vent

Pumps by



## PRODUCT SUMMARY

- Suitable for groundwater, surface water, grey water or treated effluent from a sewage treatment plant
- Structurally-reinforced tank-grade HDPE chamber
- One stainless steel automatic pumps
- Vortex impellor for high flow rates
- 600 mm x 450 mm chamber clear opening
- Access cover, 600 x 450 mm clear opening, locking, galvanised steel top with polypropylene frame, single seal, FACTA A (pedestrian duty)
- Inlets and cable ducts can be drilled on site

**Not suitable for pumping untreated sewage.**  
**See the Tricel Foullift range.**

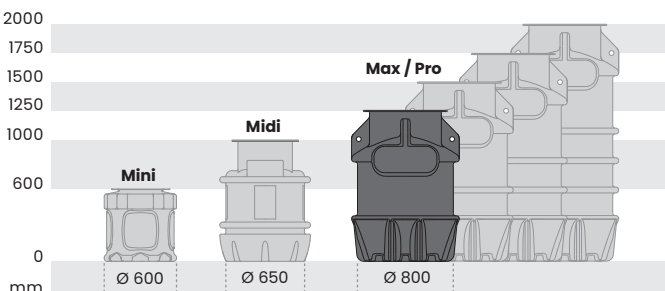

## PUMP SPECIFICATIONS

Rated current	2.5 A
P2 motor rating	250 W
RCBO Type-C rating	10 A
Max. head	9.0 m
Max. flow rate	2.8 l/s
Discharge size	1 1/4"
Free passage	10 mm
Pump cable length	10 m

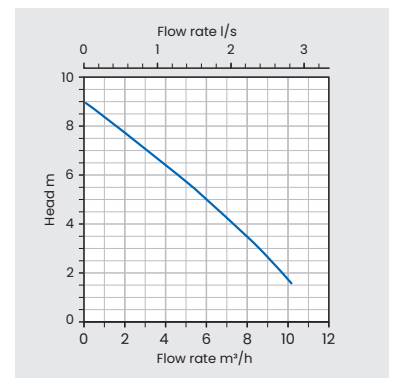

## Distance pumped at 1 l/s by pipe type

Static head	32mm OD MDPE	1 1/4" PVC	1 1/2" PVC	2" PVC
2.0 m	30 m	175 m	320 m	950 m
3.0 m	25 m	135 m	260 m	750 m
4.0 m	20 m	100 m	195 m	550 m
5.0 m	9 m	65 m	125 m	385 m
6.0 m	2 m	30 m	60 m	190 m

Static head is measured from the pump not chamber discharge.

In accordance with Tricel's normal policy of product development these specifications are subject to change without notice. Tricel (Killarney) Unlimited Company trading as Tricel.

**KEY FEATURES**

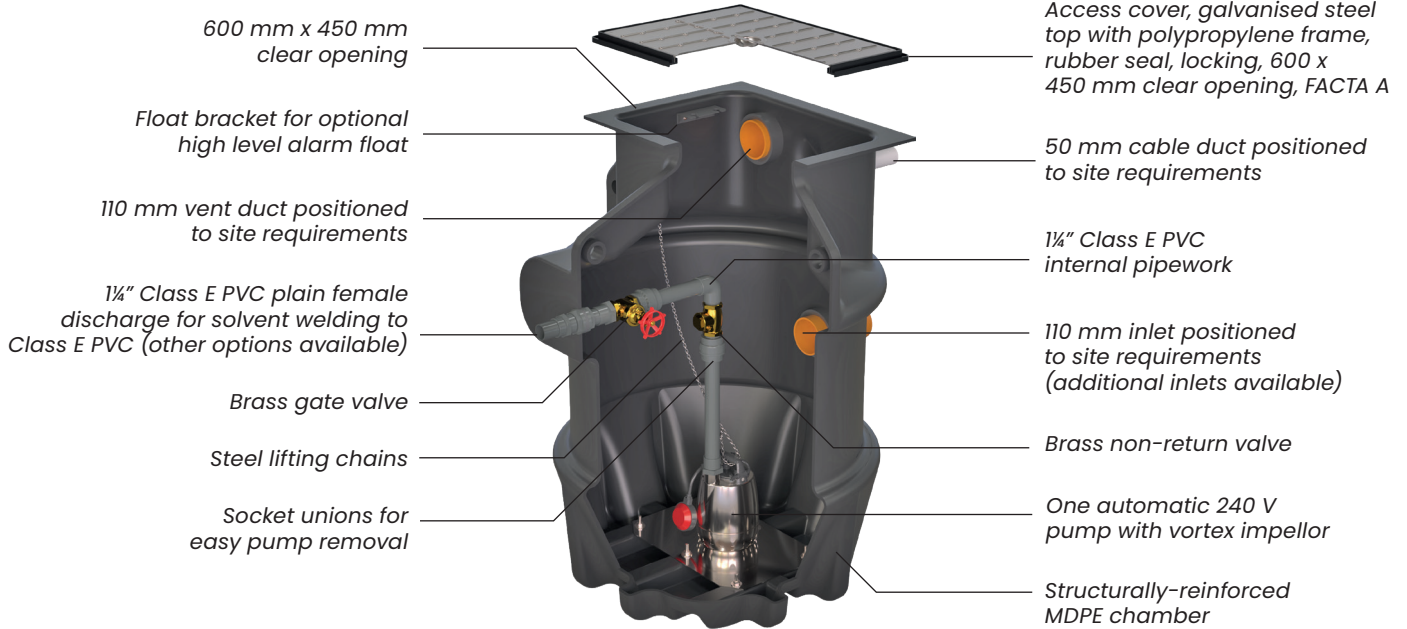
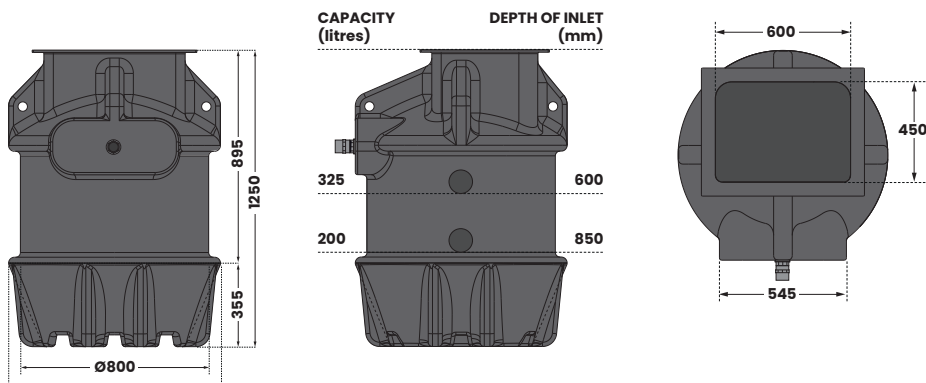

Illustration shows HydroMax 1250.

**DIMENSIONS**



Internal pipework	1 1/4" OD Class E PVC
Discharge pipework	1 1/4" OD Class E PVC
Chamber material	Tank-grade HDPE
Lifting eyes	Yes

Indicative capacity from inlet invert

**RECOMMENDED ACCESSORIES**

<p><b>Tricel AquaSafe Alarm c/w Sump Float Kit</b></p> <p>High level alarm alert HLA recorded alert Service due alert Volt-free contacts Alarm battery backup</p> <p>106993</p>	<p><b>Inlay access cover 600 x 450 mm</b></p> <p>106985</p>	<p><b>Additional connections</b></p> <p>110 mm    50 mm</p> <p>107034    107035</p>	<p><b>Adaptor for 32 mm MDPE discharge</b></p> <p>110456</p>	<p><b>PVC discharge reducer kit</b></p> <p>1 1/2" to 1 1/4"    2" to 1 1/4"</p> <p>110454    110455</p>
---	---	---	--	---