

SYSTEM OVERVIEW

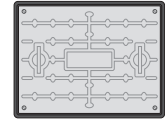

One stainless steel free-standing automatic pump



Access cover, solid top, locking, galvanised steel, PP frame, FACTA A



2" Class E PVC pipework



2" brass valves



63 mm MDPE discharge



110 mm inlet



110 mm cable duct



110 mm vent

Pumps by



PRODUCT SUMMARY

- Suitable for foul and grey water
- Structurally-reinforced tank-grade HDPE chamber
- One stainless steel free-standing automatic pump
- Vortex impellor for high flow rates
- 600 mm x 450 mm chamber clear opening
- Access cover, 600 x 450 mm clear opening, locking, galvanised steel top with polypropylene frame, single seal, FACTA A (pedestrian duty)
- Inlets, vent and cable duct can be drilled on site

PUMP SPECIFICATIONS

Rated current	5.9 A
P2 motor rating	750 W
RCBO Type-C rating	10 A
Max. head	7.7 m
Max. flow rate	6.7 l/s
Discharge size	2"
Free passage	50 mm
Pump cable length	10 m

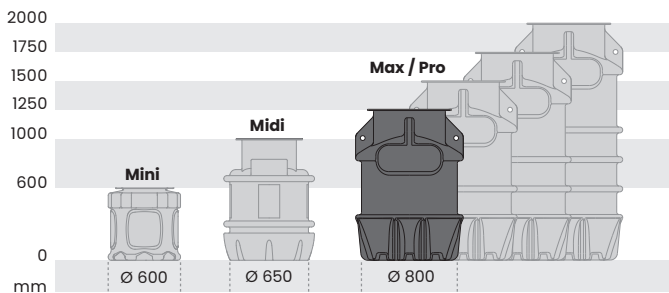
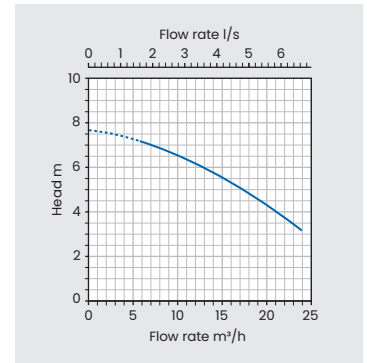

Distance pumped at 1.8 l/s (63 mm OD MDPE)

Static head m	Distance m	Static head m	Distance m
2.0	175	5.0	70
3.0	140	6.0	35
4.0	105	7.0	0

Static head is measured from the pump not chamber discharge.

KEY FEATURES

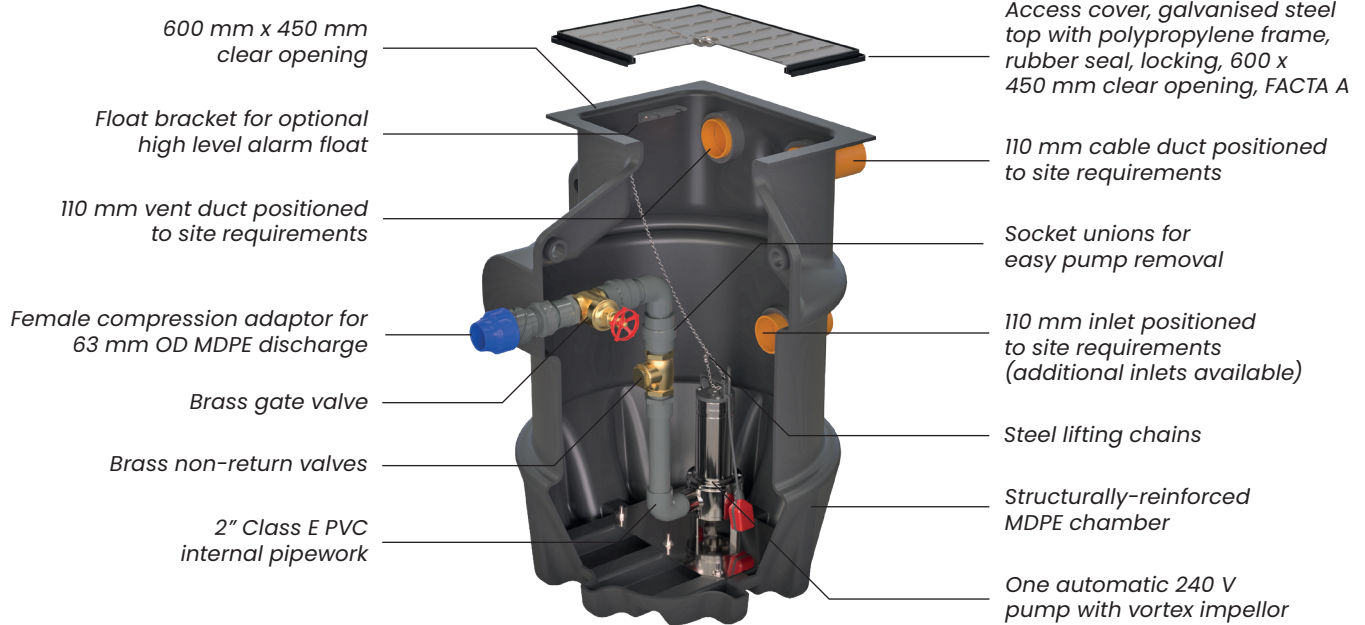

DIMENSIONS

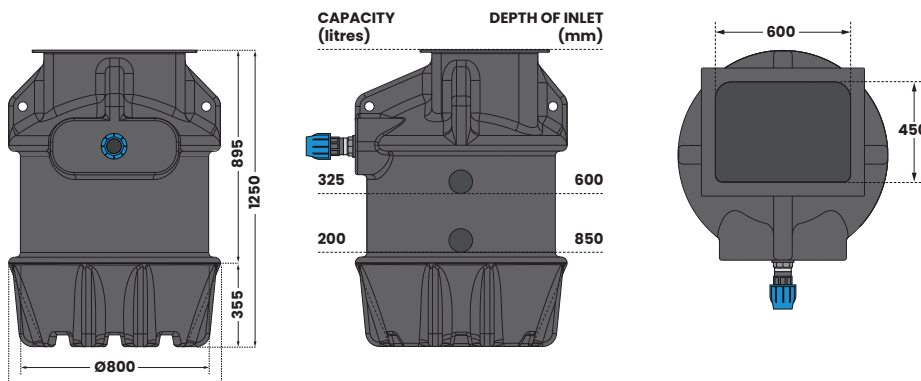

Internal pipework	2" OD Class E PVC
Discharge pipework	2" OD Class E PVC
Chamber material	Tank-grade HDPE
Lifting eyes	Yes

Indicative capacity from inlet invert 

RECOMMENDED ACCESSORIES

Tricel AquaSafe Alarm c/w Sump Float Kit



High level alarm alert
HLA recorded alert
Service due alert
Volt-free contacts
Alarm battery backup

106993

Inlay access cover 600 x 450 mm

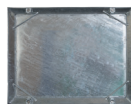

106985

Additional connections

110 mm 50 mm



107034 107035