

GRP Cold Water Storage Tanks
Manufacturing Tanks Since 1973



TRICEL

WATER STORAGE

Mixed
**One Piece
Tanks**



www.tricel.ie

Table Content

1	Guidelines for locating water tanks	2
1.1	General	2
1.1.1	Water tanks on top of buildings.....	2
1.1.2	Water tanks on elevated structures	2
1.1.3	Potable water tanks.....	2
2	One piece tanks	3
3	Condensation trays.....	4
4	Tanks insulated and finished to Format	4
5	Pipe connections for cold water storage tanks	5
6	Pipe connections for insulated cold water storage tanks.....	5
7	Format 30 fittings	6
7.1	Screened airinlet vent.	6
7.2	Screened overflow	6
8	Maintenance recommendations for one piece water storage tanks	7
9	Glossary of terms	7

1 Guidelines for locating water tanks

1.1 General

The following recommendations are generally for elevated tanks, as tanks at elevated positions can cause serious damage to the surrounding area in the event of wall, pipe or structural support failure resulting in water spilling out at a fast rate. Consideration must be given to minimise the effects of such an occurrence, in terms of the positioning of the tank and regular inspection.

- Water tanks should be located to prevent water damage or consequential loss in the event of leakage howsoever occurring.
- All tanks which are located above water sensitive areas should have a bund wall around them with adequate evacuation ducts.
- All other tanks should have condensation or drip trays to prevent nuisance damage and to keep floors dry.

Problem may arise with tanks due to, lack of maintenance, failure of the structural supports underneath the tanks, contaminated water attacking the internal fittings, ball valve failure where overflows were not fitted, vandalism etc.

1.1.1 Water tanks on top of buildings

Water tanks located on top of any buildings should be sited at least 1.2 meters away from the edge of the building.

It would be preferable if the water tank was sited 1.5 times the height of the tank away from the edge of the building. In the event of failure, this would allow the water to spread itself over a much wider area before spilling over the edge of the building and possibly taking personnel or debris with it.

1.1.2 Water tanks on elevated structures

For water tanks located on top of elevated structures, a walkway of at least 1 meter should be provided all around the water tank to allow for maintenance and inspection. This walkway should comply with health and safety regulations.

1.1.3 Potable water tanks

To comply with the Health & Safety Executive regulations on the Control of Legionellosis 2008, Cold Water Storage Tanks must be located in areas that are "readily accessible for cleaning". Regular Maintenance and Inspections as required by Health & Safety Legislation.

2 One piece tanks

Tricel (Killarney) Unlimited Company manufactures a variety of one piece cold water storage tanks. They are durable, one piece constructions, that are easy to install and represent excellent value for money. These come in sizes from 45 to 2275 Litres. One piece tanks can also be supplied insulated to Format 30, thus meeting Dublin Corporation requirements for break tanks.

The following sizes are available ex-stock

		Non - Insulated			Insulated		
Litres	Gallons	Length	Width	Height	Length	Width	Height
45	10	495	370	345	495	370	345
114	25	1180	505	340	1210	540	350
182	40	1030	510	457	1055	550	480
182	40	670	530	565	700	575	575
227	50	1142	500	465	1240	535	480
318	70	1230	575	584	1240	585	585
454	100	1425	725	585	1448	737	599
454	100	1040	761	680	1185	800	736
682	150	1630	1045	535	1725	1120	535
909	200	1620	1040	685	1725	1120	690
909	200	1300	950	880	1440	1135	890
1136	250	1670	1075	845	1725	1120	845
1363	300	1665	1235	845	1690	1270	935
1818	400	2520	1290	610	2520	1390	775
2275	500	1880	1380	1125	1910	1405	1230
2700	600				2030	1500	1290
3637	800	2665	1775	965	2715	1800	1015
4546	1000	2665	1715	1245	2665	1715	1320

- All of the above capacities are nominal.
- Insulated one piece tanks are complete with insulated covers.
- GRP covers and condensation trays are available for all sizes. Condensation trays are designed where their measurements are no greater than the length and width of the tank.
- When tanks are installed, space is required above for access.

It is important that the base of these tanks be fully supported in use.

- Tricel (Killarney) Unlimited Company manufacture condensation trays to suit all sizes of water storage tanks.
- Ensure that the base of the cistern is adequately uniformly supported over its whole area.
- Support and align the pipe so as not to distort the tank, and do not overtighten the back nuts.
- Ensure that the circular holes for fixing pipes have a clean edge, free from notches and cut them with a hole saw or drill them with a sharp cutter.
- Position the tank so that it is not in close proximity to any source of heat.
- The tank should not be left unattended during commissioning.
- Check that the internal stays are in place
- Adequate overflows should be fitted to prevent the tank from being pressurised.
- Tanks in exposed places may be susceptible to movement in high winds especially when empty.

3 Condensation trays

- Tricel (Killarney) Unlimited Company manufacture condensation trays to suit our range of one- piece water tanks. We can also manufacture bespoke condensation trays.
- Condensation trays should be used in any instance where condensation, drips from pipe work or from tanks could cause nuisance damage or render floors wet and slippery
- Condensation trays should be water tested at time of testing the tank.

A condensation tray is not a substitute for a bund wall or for tanking out a room

Appropriate overflows must be fitted as close as possible to the base of the tray, these must be fitted before the tank is filled.

4 Tanks insulated and finished to Format

- Current legislation state that water hot or cold. In any premises that might be used for human consumption must be of potable quality.
- In addition to tank material specifications, there are now further requirements for lid design, the screening of vents, breathers, overflows, warning tell tale pipes and the provision of insulation which will help prevent freezing and also help keep water as cool as practicable, ideally less than 20°C.
- Format 30 is Tricel (Killarney) Unlimited Company description of tanks with covers, complete with screened vents, overflows, warning pipes etc and having side wall and lid with a (u) value of 2.5/m²K. This value meets the requirements of section 30 of the water bye laws in the majority of situations. Tanks in boiler rooms etc may also need additional base insulation. The purchaser can specify extra requirements or thermal transmittance after considering the period of protection necessary, the tank location and the surrounding conditions.

Please note that insulation slows down but does not prevent heat loss or gain protracted periods.

Additional information is available in BS EN 806 & BS 8558.

5 Pipe connections for cold water storage tanks

- If the tank is to be drained down at a fast rate or by pumps etc., Tricel (Killarney) Unlimited Company should be informed so that adequate vents can be placed on the tank. The standard vent is 1"
- Connections of 100mm (4") nominal bore or over require studded flange pads to suit BS 10:2009, table D&E flanges for pipework connections.
- Connections below 100mm (4") nominal bore may be made by cutting holes in situ. First determine whether single or double sided connections are required and cut hole in panel to suit external pipe diameter.
- For connections over 50mm (2") nominal bore use two flanges screwed BS21 taper thread, drilled to BS10. Offer one flange to panel concentric with hole and transfer drill bolt holes into panel. Set one flange to external pipe and using appropriate gaskets, assemble external flanged pipe using other flange as an internal backing plate. Finally bolt up.
- For double sided connections proceed as above, replacing internal flange with the required fitting, e.g. ball valve, strainer basket etc.
- For connections of 50mm (2") nominal bore or less proceed as above or alternatively use threaded flanges or back nuts (with rubber gaskets) on standard long screw to BS1387.

All pipework must be self supporting. If welded or brazed-on flanges are used, all heat must be dissipated before connections are made to the tank. Holes may be cut with normal metal working tools.

6 Pipe connections for insulated cold water storage tanks

The areas where pipe connections can be made on insulated tanks are more restricted than in standard tanks, there is a recess in the insulation to allow for the pipe connection. Standard insulated tanks come with three insulation recesses. More can be supplied if required.

Recesses for connections can be made in different locations but Tricel (Killarney) Unlimited Company must be notified of this prior to order.

7 Format 30 fittings

7.1 Screened airinlet vent.

One of these is to be fitted to the lid in every Format 30 Tank, the hole for the vent will be pre- drilled in the lid panel. Larger tanks may require more than one vent.

Note: During commissioning the air inlet vent should be checked to ensure that it is fitted correctly to the tank.

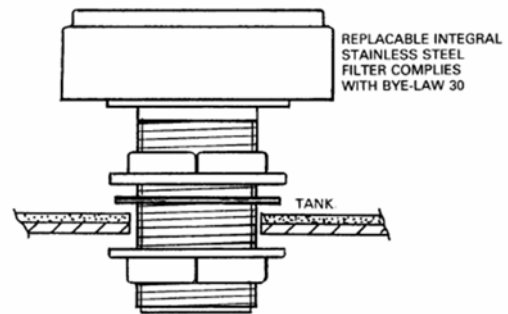

7.2 Screened overflow

A 1½" screened overflow is supplied with each Format 30 tank. Please contact us if a different size is required. These are not fitted by Tricel (Killarney) Unlimited Company.

Overflows larger than 1½" have a different configuration.

Warning or tell tale pipes if specified must also be screened.

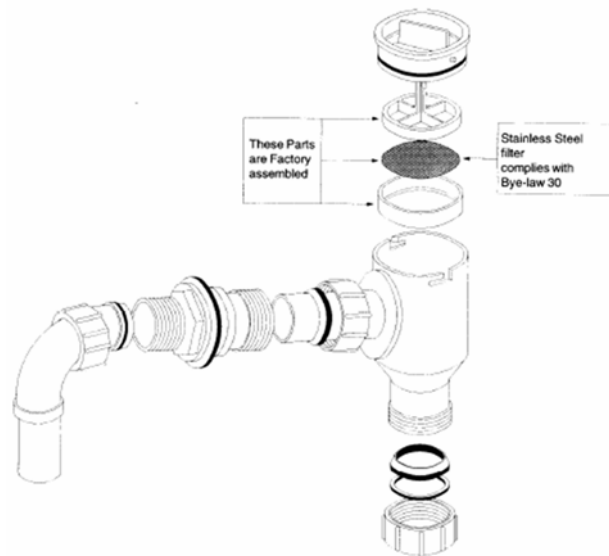

Byelaw 30 fittings

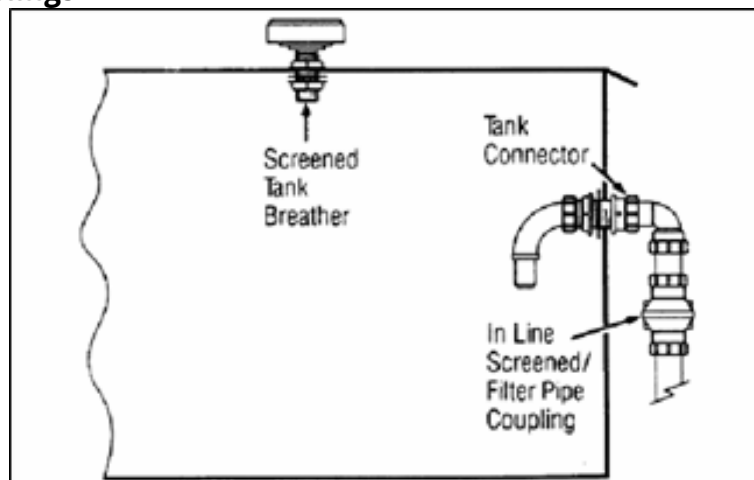

The overflows should be twice the cross section area of the inlet

8 Maintenance recommendations for one piece water storage tanks

Maintenance interval: Minimum of once yearly.

Checklist

1. All internal supports should be checked for corrosion, if corrosion is found it should be rectified immediately.
2. Check generally for leaks and drips.
3. Check that all pipework connected to the tank is suitably braced.
4. Check that the structural supports under the tank is in good condition.
5. If overflow and/or air inlet screens are fitted, check that they have not become blocked.
6. If insulated, check that insulation and the manhole is securely fixed and not damaged, if they are damaged then the tank is not in compliance with Byelaw 30.
7. If not insulated in accordance with Byelaw 30, ensure the persons cannot consume the water from the tank. We can advise on upgrading the tank to Byelaw 30 standard.
8. If there is a condensation tray with the tank, ensure that it has an overflow fitted and that it had not been damaged.
9. If the tank has a cover and is sited out of doors, check that the cover has not suffered structural damage and that it is securely bolted down.
10. If the area underneath/adjacent to the tank has become water sensitive check that the tank room is bunded with adequate escape ducts.
11. If the tank room is bunded, check that it is in good condition.

Note: Further information on the health and safety aspect, reference water quality is available in BS6700.

9 Glossary of terms

One piece tank: Rectangular fixed containers assembled for the storage of water at atmospheric pressure and at a maximum temperature of 30°C

Note: This temperature is higher than is acceptable for drinking water, which should not normally exceed 20°C.

Nominal capacity: Volume contained in a tank, measured up to the top edge of the side walls.
Actual capacity: volume contained in the tank up to the maximum working level, this can be between 10 and 50% less than the nominal capacity depending on the size of the tank.

Bund wall: Structure situated underneath water tanks. Its purpose is to protect the building from water damage. All water tanks located above areas that are water sensitive should be bunded.

Vent: Opening to the atmosphere to allow for the movement of air resulting from changes in the water level so that the water always remains at atmospheric pressure.

Warning pipe: Pipe so fixed that its outlet, whether inside or outside a building, is in a conspicuous position where the discharge of water can be readily seen.

Overflow pipe: Pipe connected to the tank to discharge any overflow therefrom.

Note: We recommend the installation of two tanks in buildings as this will facilitate maintenance of tanks without effecting the water supply to the building.

Leakage test: The duration of the test should be a minimum of 24 hours, commencing at least 2 hours after the tank has been filled. The tank should be inspected at regular intervals and not deserted during commissioning (first filling with water). The leakage test is not carried out by Tricel (Killarney) Unlimited Company.

BS EN 13280:2001. Specification for glass fibre reinforced cisterns of one-piece and sectional construction, for the storage, above ground, of cold water.

In accordance with Tricel (Killarney) Unlimited Company, normal policy of product development, this specification is subject to change without notice.

Note:

Tricel (Killarney) Unlimited Company believe that the information contained in this brochure is accurate, and is printed for information only. No warrants, express or implied, are contained therein, nor does any legal liability attach to Tricel (Killarney) Unlimited Company for any reason whatsoever. Property rights of the subject belong to Tricel (Killarney) Unlimited Company, and transfer of these rights is not granted by possession of this document. Sep 2019



Tricel (Killarney) Unlimited Company, Ballyspillane Industrial Estate, Killarney, Co. Kerry, V93 X253, Ireland.

Tel: +353 (0)64 663 2421 | **Email:** sales@ie.tricel.eu | www.ie.tricel.eu

In accordance with Tricel (Killarney) normal policy of product development this specification is subject to change without notice.